



(Biological Optical Technologies)

Dedicated to Mainstreaming Live-Cell Microscopy into Medical Research and Clinical Practice

The products contained in this catalog were developed to meet the demanding requirements of the current renaissance in microscopy. This revolution in microscopy includes: confocal imaging, standing-wave microscopy, multi-probe fluorescence microscopy, computerized imaging, movie loops, etc.

Live-cell microscopy environmental control systems require careful planning and attention to every detail. This catalog has been prepared to assist in the selection of a variety of advanced products and technologies designed specifically for the live-cell microscopist. In addition to being a resource of technologies for the experienced microscopist, it can be used as an informative guide for those just entering the exciting and demanding world of live-cell microscopy. We wish you much success in your work and hope you find our products and support beneficial. If you do not find the live-cell micro-observation products you need in this catalog, please call us and discuss your specific problem. We would be happy to share our knowledge base with you.

Bioptechs can be reached Monday through Friday, 9:00 AM to 5:00 PM Eastern Time. All calls are answered by a competent human being. We will never use those annoying automated phone systems during business hours!!!

Voice *Toll Free 877-LIVE-CEL (548-3235) U.S. and Canada
724-282-7145 (Sales and Technical assistance)*

Fax *724-282-0745 (24 hours a day)*

E-Mail *info@bioptechs.com (Checked regularly)*

Web *http://www.bioptechs.com (Includes automatic E-mail)*



What is Biotechs?

Biotechs is an innovative American optical engineering company that designs, develops, and manufactures live-cell microscopy environmental control instrumentation for qualitative and/or quantitative light microscopy. Our products are dedicated to the science of live-cell microscopy and include imaging systems, micro-observation environmental control instruments, perfusion pumps, bio-compatible tubing for cell culture, and specialized fittings and adapters as well as numerous supplemental items. Biotechs has developed and patented several technologies which are indispensable to the live-cell microscopist which include:

- Microaqueduct laminar perfusion in a temperature-controlled optical cavity
- A unique symmetric closure mechanism for optical cavities
- Objective thermal regulation devices to reduce temperature gradients for high N.A. objectives
- A unique hybrid culture dish system specifically designed for live-cell microscopy which utilizes an advanced technique of first-surface thermal transfer to quickly, accurately, and uniformly maintain the thermal, optical, and fluid requirements of cultured cells and tissue

Biotechs products and techniques have demonstrated their ability to out-perform traditional methodologies and have become the established standard method of micro-environmental control in many leading universities and pharmaceutical companies. Biotechs manufactures more than 80 standardized products and provides customers with the availability of a variety of related products and services.

Mission:

Man is a highly complex biological structure whose composition is being studied at every level from molecular structure to behavioral science. Within this range lies the area of cell biology. Until the past ten years, most of the microscopy of cells has been done with fixed cells. The information gathered has been limited to only that which can be derived from the dead remains of cells. Now scientists have a new set of tools available to them, such as highly sensitive electronic cameras interfaced to computers and microscopes that are able to optically detect minute traces of specialized dyes or indicators. This instrumentation can provide both visual and quantitative information about processes and behaviors within the cell that were previously unobtainable. Biotechs recognizes the importance of the ability to reproduce the cells' host environment on the microscope, without sacrificing optical functionality, as a critical component of modern biological experimentation. Our systems are used primarily in basic research applications. We are also developing new protocols for the analyzation of live primary cells obtained from human patients to determine the most appropriate treatment as a routine method of health care. Biotechs' mission is to develop and manufacture micro-environmental control systems to enable advancements in live-cell imaging for research and clinical applications.

Biotechs products:

All Biotechs' products are designed, manufactured, and tested at the Biotechs' facility in Butler, PA, and are backed by a one-year warranty. Biotechs live-cell systems provide full optical compatibility with all modes of light microscopy. Biotechs' controllers feature a real-time temperature display and an ultra-fast learning curve to compensate for temperature changes due to surface evaporation or perfusion. The standard controllers have a special out-of-limit alarm circuitry to ensure the safety of the specimens and a temperature range from ambient to 50°C. Extended ranges from ambient to 100°C are available upon request. Our temperature control systems are economically adaptable to a variety of critical temperature control applications. Biotechs also offers opto-electronic and opto-mechanical design services specializing in light microscopy. Our in-house machine shop affords the luxury of making modifications or prototyping new designs quickly and economically.

Applications include but not limited to:

AIDS research	Calcium ratioing	In vitro fertilization (IVF)
Anesthesiology	Cancer cell migration through tissue	Morphology
Apoptosis	Cardiac myocyte recording	Muscle force transduction
Artificial membrane	Chemo assay of cancer patient tumor cells	Neuronal stimulation & recording
Avian research	Developmental biology	Soft tissue microscopy
Bacteriology	Drug testing & development	Tissue engineering
Brain slice	Induced change assays	Toxicology



Contents

Observation of Live Cells on the Light Microscope	4 - 9
Open Dish Systems (Delta T Culture Dish System)	14 - 26
Options for the Delta T Culture Dish System	16 - 26
Membrane Micro-Observation	20
Brain Slice Micro-Observation	21
Open System Perfusion	22
Delta T Stage Adapters	23
Accessories	26
Closed Chamber Systems (FCS2 System)	27 - 29
Closed System Perfusion (FCS2)	30
Options for the FCS2	32
Cooled FCS2	33
FCS2 Stage Adapters	34
FCS3 Upright Closed System Chamber	35 - 37
Closed System Perfusion (FCS3)	38
Objective Warming	39
Objective Cooling	40
Perfusion Systems	41
Dual Pump Control	43
Perfusion Tubing	44
Reference Information	45
System Profile Guide	46
Checklist for Closed System Chambers	47
Checklist for Open System Chambers	48
How to Size Your Objective	49
Price Lists	50 - 52
User References	53 - 54



Observation of Live Cells on the Light Microscope

Reproduced and edited from an invited article appearing in
Cells A Laboratory Manual, Volume 2, pg 75.1 - 75.13.
Daniel C. Focht, David L. Spector, Robert D. Goldman, Leslie A. Leinwand

Introduction

The direct observation of the dynamic properties of known molecular species *in vivo* has been made possible through a variety of molecular, biochemical, immunological, and imaging techniques. For example, the now widespread use of GFP tags permits the direct observation of specific cellular constituents *in vivo*. However, in order to observe live and healthy mammalian cells in the microscope field, there are technical problems with respect to the maintenance of temperature, pH, etc., of the culture medium. This is not a significant problem when observing non-mammalian or plant cells. Typically, live-cell experiments can be classified into two categories; developmental studies to establish natural behavior, or induced change to study the effects of a controlled factor. The correlation between *in vitro* and *in vivo* phenomena is paramount for mammalian live-cell investigations. Therefore, it is of the utmost importance to simulate the host conditions of the isolated specimen accurately during live-cell microscopy. This chapter describes multiple approaches for the micro-observation of live cells.

History

Specimens used for early microscopy were often alive, or at least temporarily alive. Techniques for fixing and staining were developed along with advances in microscopy. As microscope optics improved, the limitations of the optical system defined the necessity for specimen preparation. Microscopists played a game of give and take based on optical constraints. Magnification, numerical aperture, resolution limits, working distance, and correction for chromatic aberration were recognized as interrelated factors. In addition, methods of illumination to include bright-field, dark-field, phase, and fluorescence were brought into mainstream microscopy. With these forms of microscopy available, it was accepted that the specimen needed to be prepared to meet the optical limitations of the microscope. These preparations most often required fixing the specimen. Cameras using film were combined with microscopes to document images. Conventional film-based photomicroscopy was suitable for most bright-field, dark-field, and fixed fluorescence images because exposure time was of no concern. Time lapse images of live cells were typically acquired using bright-field modes because the low sensitivity of film required high light levels. Live-cell fluorescence movies were not possible due to the toxicity of the dyes and phototoxic effect of long exposures. Although fixed cells yield less information in comparison to live specimens, there are some advantages. Fixed cells are flatter and last longer. They don't move or require constant care, and they can be stained with a variety of compounds to selectively enhance contrast. Most anti-fade reagents are compatible with fixed (but not live) cells. When images of live cells were recorded on conventional film, the microscopist was limited by the sensitivity and resolution of the film, which also limited the kinds of experiments that could be done. Film has many limitations when compared to modern, intensified, or cooled CCD cameras, and photomultiplier scanning techniques. Consequently, early live-cell chambers were inherently limited by the associated technology. Early

microscopes did not have the image-contrasting enhancements that modern microscopes have. Therefore, the live-cell microscopy that was done during the film era was either poor by today's standard or limited to high-contrast specimens.

Recent Technical Developments

The following developments have made quantitative live-cell microscopy easier:

- The development of image-contrast enhancement techniques such as, DIC, Hoffman, Phase, Varel, Fluorescence, Multi Photon, and Confocal Microscopy
- Video cameras and quantitative CCD cameras capable of low-light detection and electronic contrast stretching
- Desktop computers bringing quantitative imaging capabilities into mainstream science
- Advances in the development of dyes and labeling techniques
- Micro-environmental control systems developed to keep pace with the associated technologies

Today these technologies have provided the instrumental foundation for conducting live-cell experiments, requiring less time for engineering equipment, and leaving the researcher more time for biology (Pentz and Schulle 1981; Webb 1986; Shotton 1988). Cells can be maintained in an incubator, but putting the microscope in an incubator is impractical. The logical extension is to duplicate incubator conditions on the stage of the microscope. Cells need certain known regulated conditions such as nutrients, removal of waste products, carbon dioxide, a growth surface matrix or lattice in the case of tissue, and temperature control. In order for cells to be visualized, they must be in an environment that is both conducive to their viability and compatible with the microscope's optical limitations.

Micro-Environmental Chambers

There are two basic forms of specimen containment and micro-environmental control. In applications where single-cell analysis is appropriate, the specimen must be contained in an optical enclosure. The two most commonly used methods of micro-observation are the open culture dish in which fluids are open to the atmosphere, and the closed system, which is sealed. Typical open culture dish systems are the simplest form of live-cell observation and are generally well suited for short-term experiments or applications where physical access to the cells is necessary. The traditional method of growing cells in a container, then observing the cells on a peripherally heated microscope stage, is adequate for investigations requiring only basic modes of relatively low-resolution microscopy. For more advanced investigations requiring high-resolution imaging using fluorescence, DIC, 2 Photon, and/or confocal modes, a more advanced environmental control system should be used. Various types of simple culture chambers were developed for observing live cells under the microscope. Some of the more popular types include the Maximow Chamber, the Romicron Chamber, and the Rose Chamber. The Maximow Chamber was the simplest early chamber, consisting of a thick micro-culture depression slide made of heavy glass. An earlier version of a closed system

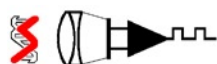

was constructed by placing a gasket between a coverslip and a slide or two coverslips. The Romicon chamber is also made of plate glass, but with an optically ground cylindrical depression centered in the slide so that the bottom of the depression is optically clear. A double-coverslip technique is used to cover the chamber. This consists of a larger, usually rectangular, slide upon which is placed a smaller circular coverslip with the primary explant or cells of interest in medium. The smaller coverslip is held onto the larger slide by capillary action. This double cover is then inverted to span across the cylindrical chamber and sealed (typically with beeswax). This sort of chamber is appropriate for use with experiments where perfusion is not needed and the experiment is of short duration so that pH, CO₂, temperature, and the buildup of waste products are not common problems. The Rose Chamber is a more elaborate version of a simple closed chamber, consisting of a thick plate glass slide having a circular opening through the slide to form the chamber. The top and bottom of the chamber are sealed, typically with coverslips placed above and below the opening through the slide, often with a rubber O-ring or gasket between the slide and a coverslip to allow perfusion into and out of the chamber. This sandwich of coverslip, O-ring, slide and coverslip is held together by metal rims on the top and bottom of the sandwich that may be screwed together to form a tight seal. Although these simple chambers may be suitable for many purposes, the more sophisticated chambers described in this chapter generally provide a more advanced environmental control system appropriate for more complex experimental observations.

Why a Chamber?

A chamber can be any structure with optical, fluid, and temperature control capabilities. This may be a simple culture dish or flask, or a complex dedicated live-cell environmental system.

- Observation of single cells *in vivo* with traditional diffraction limited optics is difficult and sometimes impossible. Therefore, cells have to be isolated from their host and studied in an external optical culturing environment.
- The specimen needs to be studied on a flat transparent surface to be compatible with imaging.
- Cells also need a fluid containment structure for liquid media of a suitable volume to maintain their viability.
- Perfusion may be needed to maintain control of pH, for removal of waste products and to add reagents that will alter cellular physiology.

Types of Environmental Control Techniques

Aside from the optical and physical embodiment of a chamber, a number of methods of temperature control are used. This is especially important in studies of mammalian cells. Thermal regulation devices employ a variety of techniques including: warmed airstream specimen warmers, electro-resistive heating elements, Peltier effect, thermally controlled fluids, infrared illumination, and first-surface thermal transfer. Temperature control factors include: range, accuracy, speed, and recovery time. Over the years, temperature has been controlled using extreme measures, such as placing the entire microscope in an incubator with only the eyepieces exposed. This is very expensive and detrimental to the microscope. Another option has been to encase the stage of the microscope with an acrylic enclosure while pumping in heated air. The most popular option is to use a heated plate or stage warmer to surround the culture dish or coverslip chamber. The least desirable techniques are

warm air blowers and/or infrared lamps surrounding the stage. This is because these devices involve maintaining temperature by switching heaters on and off continuously, frequently causing focal drift and contamination. An alternative solution to the above techniques utilizes first-surface thermal transfer to regulate cell temperature. An optical cavity or coverslip can be temperature controlled by passing a current through an electrically conductive coating on one of the optical surfaces that defines the optical cavity. This technique has been proven to have many advantages over traditional methods.

The following is a list of some of the typical difficulties encountered with traditional chambers:

- Coverslip breakage that occurs during assembly
- Leakage onto and sometimes into the microscope
- Lack of flexibility to accommodate varied volumetric requirements
- Fixed flow characteristics
- Flow rates slower than biological events to be recorded
- Minimal volumes larger than required by protocol
- Inadequate temperature control
- Lack of compatibility with all modes of microscopy

Selecting a Micro-Environmental System

Microscope Factors

Generally, inverted microscopes are used for cultured cells, but in some cases, an upright microscope is appropriate. When using an upright microscope, some concessions have to be made depending on the intended modes of microscopy. For example, special care must be taken in determining the magnification, working distance, and numerical aperture, all of which are related to the depth of field. It is also important to recognize that fluid coupled objectives will need to be temperature controlled when used with mammalian specimens. If a transmitted light condenser will be used, allowance must be made for the working distance, physical size, and proximity to the chamber. The geometry of the stage also must be matched or mated to the environmental chamber. Inverted microscopes are far more compatible with live-cell experiments for the following reasons: cells gravitate downward, and the condenser can be employed without interference from the stage. Upright microscopes have two main disadvantages in open dish applications; the first being the inability to fully utilize high N.A. objectives, and the other being the position of the condenser to the specimen is limited by the stage.

Micro-Environment Physical Characteristics

When using an open system, the following characteristics need to be addressed; volume, clear aperture, material, bottom thickness, geometry, evaporation and condensation, ambient light, view angle, and biocompatibility. When selecting a closed system, the following characteristics need to be addressed; fixed or variable volume, separation of optical surfaces, perfusion-flow characteristics, volume exchange rate, laminarity, shear stress, and flow channel geometry.



Typical Culture Dish Observation

In applications where cells are being observed with low numerical aperture (N.A.) objectives, an open culture dish and phase contrast or dark-field microscopy are frequently used. Today's sophisticated experiments, however, are far more demanding on the cells' environment. For example, during long-term developmental or induced-change studies, it is necessary to accurately simulate the host conditions on the microscope stage without limiting the resolution of the microscope while simultaneously maintaining the ability to change variables. This simulation should include control of temperature, medium, pH, and environmental toxicity. Medium and pH can be controlled by regulated perfusion. The toxicity of the artificial environment must be evaluated against compatibility with the specimen (Inoue 1986). Presuming the artificial environment is nontoxic or biologically inert, one of the most difficult factors to control has been temperature. With all the relevant papers on the importance of accurate temperature control and its effect on data, it should be readily apparent that temperature is a critical factor in most mammalian live-cell experiments (Taylor and Wang, 1989; Taylor et al. 1994). When using applications requiring high N.A. objectives, most investigators use carefully supported coverslips to attain optical compatibility and peripheral stage warmers to simulate the host environment. This frequently means sacrificing the accuracy of thermal control and/or adequate perfusion of the cells resulting in either inaccurate data due to compromised cells or poor images. The characteristics and limitations of traditional methods of open dish micro-observation are summarized here. (See Figure 1)

Conventional culture dishes are made of plastic, which is known to have the following characteristics:

- Non uniform optical surfaces that degrade the image
- Strain in the optical surface due to the injection molding process that prohibits the use of optical systems employing polarized light, including DIC
- Thick bottom surface prohibits the use of high N.A. objectives
- Inefficient heat transfer from the source to the cells which results in long-term temperature-stabilization cycles.

Traditional culture dish warmers are peripheral heating devices that must radiate heat through two inefficient thermally conductive mediums (air and plastic), therefore resulting in:

- Non uniform temperature distribution
- Excessive thermal transfer time during thermal recovery (on the order of minutes)
- Thermal expansion of the metal surface causing vertical displacement which is apparent during 3D imaging or confocal applications.

If these factors do not present a problem, a stage-warmer-based system is adequate and preferable. However, if the experiment requires more accurate temperature control or optical compatibility, the techniques described in the following section should be considered.

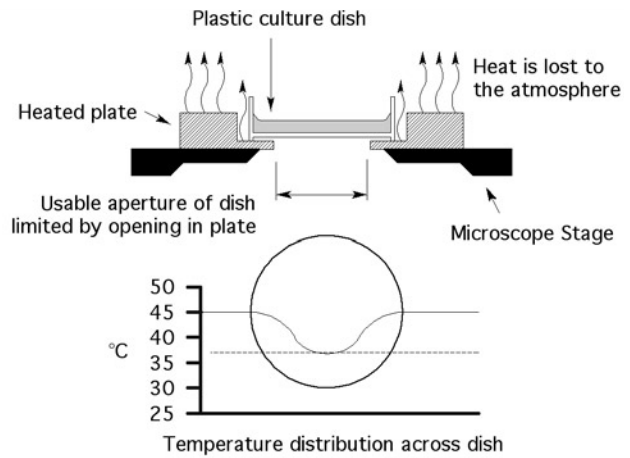

Figure 1: Traditional open culture dish microscopy. The traditional technique is limited by slow and inefficient stage heaters, resulting in non uniform temperature distribution. In addition, plastic dishes are poor conductors of heat. Thus, the temperature does not recover quickly during or after perfusion. Finally, the usable aperture of the dish is limited by the opening in the heat-transfer plate.

Advances in Culture Dish Live-Cell Systems

An alternative solution to these problems is to use a micro-environmental system that utilizes a first-surface thermal transfer technique. This technique utilizes a thin-film coating of a nearly transparent, (see Figure 2) electrically conductive coating applied to the bottom surface of a glass substrate, which is then incorporated into a hybrid disposable culture dish structure optimized for live-cell imaging. This technique provides temperature control directly to the cells through a thermistor feedback loop, which applies an electrical current through the coated underside of the glass substrate (See Figure 3). The thermal response using this technique is as fast as 0.1°C/sec. Because of this fast response time, the controller can regulate the current control within seconds, making it possible to compensate for temperature changes that occur in the dish due to surface evaporation, entropy, or perfusion. This fast response time enables the addition of high-speed safety circuitry to protect the cells in the event of error. This technique offers high resolution imaging capabilities through a uniform glass surface free of strain and is available in a variety of thicknesses, including the popular No. 1.5 coverglass for high N.A. applications. The dish environment is compatible with all modes of microscopy including, but not limited to, bright-field, dark-field, phase, DIC, fluorescence, reflection interference, 2 Photon, and confocal. The first-surface thermal transfer technique on a coverslip, introduced in 1993, provides the basis for many adaptations of the basic principle. Since that time, numerous applications and accessories have been developed. After becoming familiar with the accuracy, ease of use, and superior optical imaging obtainable with a first-surface thermal transfer system, it is easy to envision and implement numerous derivations for specific applications other than isolated cell culture. The following are examples of some of these uses, accessories, and benefits based on the Bioptechs Delta T Culture Dish System.



- Tissue slice specimens, natural or artificial, can be easily suspended in an optical reference plane in the dish at the appropriate focal distance from the objective.
- Transmembrane migration or diffusion of cells or ions can be dynamically observed during isolated perfusion of inhibitors or changes of ion concentration to the basilateral surface.
- Continual perfusion can be employed to maintain low-volume perfusion during long-term experiments.
- A coverglass lid is available for use during microscopy to define an optical surface above the specimen and on the surface of the liquid in the dish. When a series of images are acquired in transmitted light mode, there is a changing fluid interface between air and the surface of the medium, causing image contrast shifts. Forming an optically flat surface on top of the medium eliminates this problem.
- An electrically heated, optically transparent lid eliminates condensation from forming on the under surface of the cover.
- Cooling of the specimen can be accomplished by submerging within the dish, a ring through which refrigerant fluid is circulated.

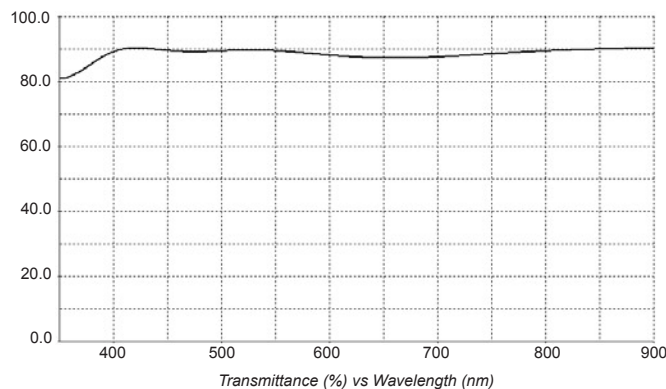

Figure 2: Transmission spectra of Indium Tin Oxide coated 0.170mm thick coverglass.

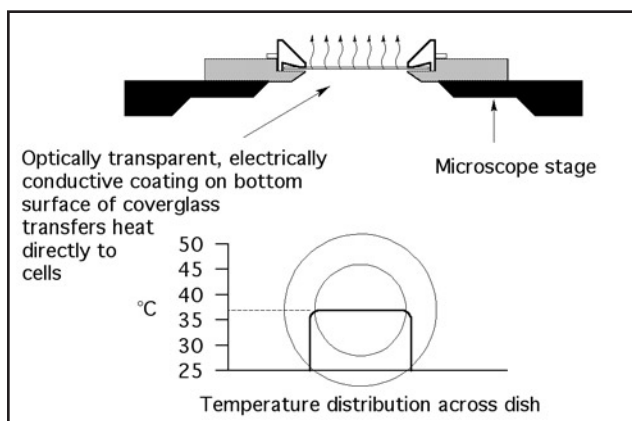

Figure 3: First-surface thermal transfer.

Some advantages of the system are the highly accurate temperature control, fast thermal recovery, and uniform temperature distribution.

Traditional Closed-System Chambers

A closed-system chamber is required when there is a need either for complete isolation of the specimen from the outside world or for the use of more advanced microscopic methods that are incompatible with the use of open dishes. In this case, cells are placed in a temperature-controlled, perfusable optical cavity or plated onto a coverslip that is part of this cavity for microscopy. There are several traditional configurations of these closed-system chambers commercially available. Nearly all of them utilize the same basic characteristics. (See Figure 4 below) Traditional closed-system chambers provide two optical surfaces separated by a perfusion ring sealed with gaskets. This sandwich is then clamped together by several other structures. With this type of enclosure, the perfusion rate, volume, and optical suitability for various modes of microscopy are interrelated. In most cases, perfusion with this configuration may result in turbulence that can dislodge cells. The limitations of this design impose a trade-off between functionality and compatibility with various modes of microscopy. Furthermore, temperature control is usually achieved through the use of peripheral heaters or warmed air blown across the stage. In either case, temperature control is not reliable or maintained within an acceptable range for critical experiments.

When selecting a closed-system chamber, the following factors need to be considered:

- Optical compatibility for the intended modes of microscopy
- Temperature control, including uniformity
- Volume of chamber
- Perfusion
- Volume exchange rate for perfusion
- Cell surface shear
- Imaging aperture
- Thermal effect of fluid coupled high N.A. objectives

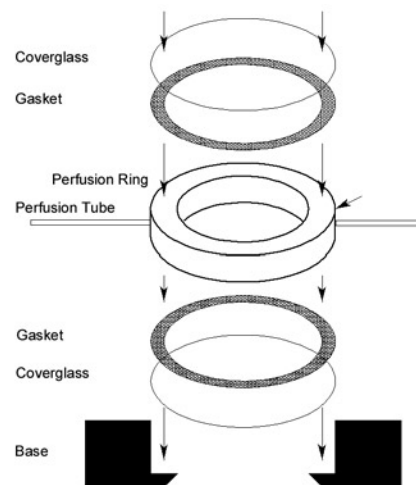

Figure 4: Traditional closed-system chamber.

Inherent Shortcomings of Traditional Closed-System Chambers

- Excessive separation between optical surfaces limits condenser N.A. in transmitted modes of microscopy
- Fixed optical cavity volume
- Requires lengthy fluid exchange rate
- Turbulent perfusion produces high cell surface shear-flow rate
- Not compatible with certain modes of light microscopy



- Difficult to load and secure with cells
- Prone to leakage

Advances in Closed-System Chambers

A solution to these problems is provided by the use of a microaqueduct perfusion technique. A microaqueduct flow live-cell, micro-observation chamber is prepared by incorporating perfusion grooves into one of the optical surfaces that define the Figure 5: Microaqueduct slide enclosure optical cavity, thereby eliminating the perfusion ring common to most other chambers and defining the optical cavity with only one gasket separating the perfusion slide from the coverslip.

The physical configuration of these grooves produces a near laminar flow region in the optical cavity. The single gasket design allows the user to define the size, volume, thickness, and shape of the optical cavity. In addition, microaqueduct perfusion

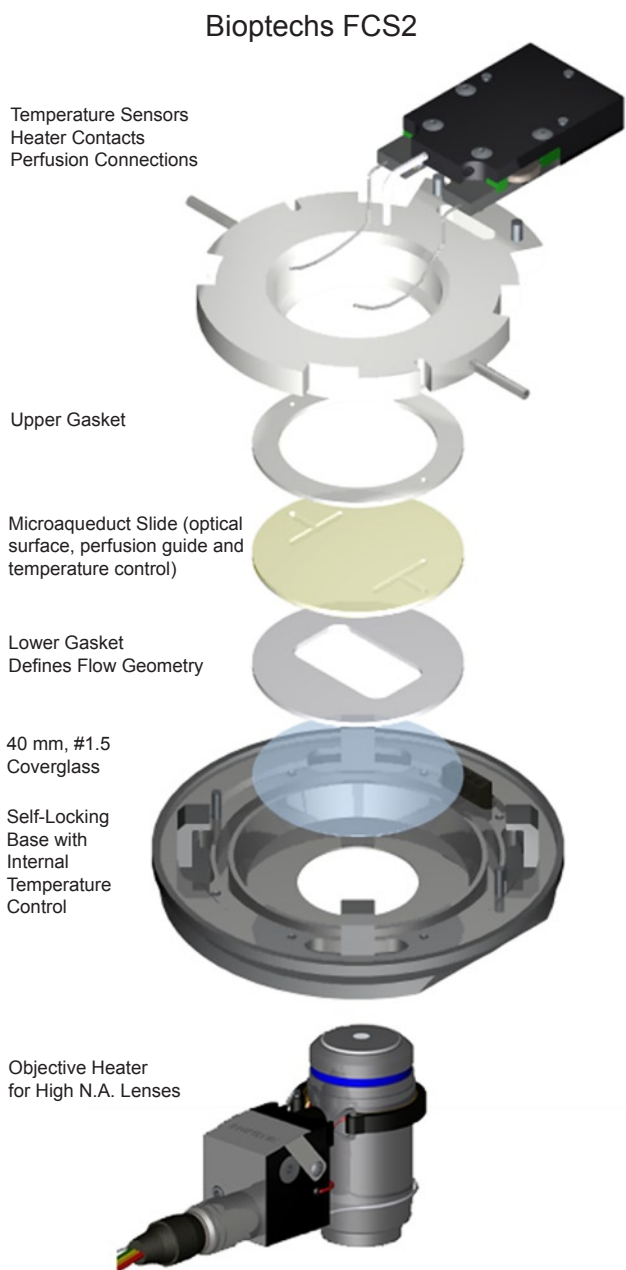

Figure 5

provides large aperture flow inputs and outputs, eliminating the problem of volume exchange rates. To further enhance the performance of this design, the first-surface thermal transfer technique (the electrically conductive, thermal controlled coating on the microaqueduct slide) was incorporated, thus adding thermal uniformity to the chamber even during experiments with periods of no flow. This system is exemplified by the Bioptechs FCS2 Closed System Chamber. (See Figure 5) Therefore, the specimen, adherent cells on a coverslip, is maintained safely in a temperature-controlled optical environment that is compatible with all modes of microscopy, including, but not limited to, low and high N.A., transmitted, bright-field, dark-field, phase, DIC, and reflected modes of fluorescence, as well as confocal. For optimal temperature control when using high N.A. lenses (immersion), an objective lens heater is required. This system is further characterized by a sophisticated temperature control system easily modified for custom applications.

High N.A. Objectives

In high N.A. imaging, it should be noted that the optical medium used to couple the objective to the coverglass will act as a heat sink. If the objective temperature is not regulated, this will result in a temperature gradient across the field of as much as 5°C. The microscope manufacturers have not yet met the live-cell researchers' needs by providing integrated temperature control for the objective. So, an external objective heater must be used. To control the temperature of the objective accurately, it is necessary to overcome the constant drain of heat from any thermally conductive mass such as the nose piece or microscope frame. The thermal characteristics of all objectives and microscopes vary considerably, making it necessary to have an efficient transfer of heat to the objective and an intelligent controller. Such a system would sense the temperature of the objective at a point close to the specimen and regulate the heat applied to the objective while taking into account the thermal mass of the objective and the ambient conditions. A device for this purpose, which particularly surrounds the upper portion of the objective central tube with a heating band and measures the thermal transfer in a gap formed between the ends of the heating bands, is exclusively available from Bioptechs, Inc. (Patent # 5,410,429). The controller regulates the heater current in such a manner that it maintains the temperature to within 0.1°C. Although the objective heater is designed to fit most objectives, it does not fit all objectives. Some objectives, especially water-coupled objectives, are particularly difficult to work with. The main problem is their large diameter and lack of adequate surface area on which to transfer heat. Sometimes their size makes it difficult, if not impossible, to have sufficient working room to focus on the specimen. The microscope manufacturers have agreed that heating of the objectives to 37°C will not harm the objectives, but they have not made any comments about daily heating. It is recommended that the objective be stored in a 37°C enclosure when not in use to reduce the possibility of detrimental effects of thermal cycling between physiological and room temperatures.

Perfusion

Perfusion is necessary for one or both of the following reasons; either experiments on live cells take place over a time span greater than cells will tolerate without fresh media, or the experiment is one in which chemical change is induced through perfusion. In both cases, it is necessary to have a method of perfusing cells in their micro-observation environment that will not impede the experiment or the acquisition of electrical,



chemical, or optical data. Due to the small fluid volume in live-cell chambers, the diaphragm effect produced at the unsupported aperture of the coverslip, and the sensitivity to shear stresses of the cells, selection of a perfusion system requires great care and, in some cases, a trade-off. The ideal perfusion pump would provide a closely controlled, purely analog flow indefinitely. This is currently not available. The three basic methods of perfusion are gravity flow, manual injection with a syringe, and mechanical pumps. Gravity flow is very inexpensive and difficult to control at flow rates necessary for microscopy. Manual syringes are ideal for adding growth factors, inhibitors, or other periodic small-volume fluids. Mechanical pumps are the most reliable and are available in two popular forms: motorized syringe and peristaltic. The syringe pump is limited in volume for long-term experiments and subject to flow variations on a micro-flow scale due to temporary sticking of the plunger. Use caution in selecting a pump. Stepper motor-driven pumps can be controlled to very slow flow rates, but the instantaneous rotor movement produces hydrodynamic pulses that can cause the coverslip to flex or the cells to dislodge with the sudden pulse. Before deciding which type is the most appropriate for the application, consider the following variables:

- Expected flow rate
- Uniformity of flow rate over various time scales
- Range of flow rate and total volume of flow
- Quality of flow

One pump that has excellent flow characteristics for microscopy especially at slow flow rates is the model 720 Micro-Perfusion Pump (INSTECH). It is a peristaltic pump small enough to be held in the palm of the hand. It uses a tachometer regulated DC motor and a multistage, step-down gear box to drive the roller spindle, resulting in a flow profile free from sudden pulsations typical of most peristaltic pumps. It is equipped with an internal speed control. It can also be interfaced to a computer through an analog interface. The pump can be configured to provide single-channel perfusion for closed chambers or dual-channel for continuous self-leveling perfusion in an open chamber. Flow rates are adjustable from 2 to 180 ml/hour.

Tubing

For live-cell perfusion experiments, it is prudent to use USP Class VI certified tubing for maximum biocompatibility. There are three types of tubing that meet this requirement: PharMed (available through Fisher, VWR, and other suppliers), Tygon 2275, and C-Flex. Although PharMed is well suited for cell culture, it has one main drawback. It is opaque. The perfusate is not visible through the tubing. Therefore, bubbles that may form in the tubing are hidden from view. This is a major concern when using a closed-system chamber because bubbles in a narrow optical chamber become lodged by surface tension. C-Flex and Tygon 2275 tubing in 1/16 inch size is available nearly clear and not prone to leaching plasticizers into the perfusate.

References

- DeBiasio R., G.R. Bright, L.A. Ernst, A.S. Waggoner, and D.L. Taylor.** 1987. Five parameter fluorescence imaging: Wound healing of living Swiss 3T3 cells. *J. Cell Biol.* 105: 1613-1622.
- Focht D.C., Latimer J.J.** 2001. Cellular Micro-Observation in Pharmaceutical Research. *Pharmaceutical Visions*, Autumn 2001: 18-22.
- Focht D. C. Farkas D.L.** Mammalian Live-Cell Microscopy Environmental Control. *Cell Vision, Journal of Analytical Morphology.* 1995, Vol 2 No.6 450-454.
- Farkas D. L., T.B. Ballou, G.W. Fisher, and D.L. Taylor.** 1995. From in vitro to in vivo by dynamic multi-wavelength imaging. *SPIE Prog. Biomed. Optics* 2386: 138-149.
- Farkas D.L., G. Baxter, R.R. DeBiasio, A. Gough, M.A. Nederlof, D. Pane, J. Pane, D.R. Patek, K.W. Ryan, and D.L. Taylor.** 1993. Multimode light microscopy and the dynamics of molecules, cells, and tissues. *Annu. Rev. of Physiol.* 55: 785-817.
- Inoue, S.** 1986 *Video Microscopy.* Plenum Press, New York.
- Pentz S. and H. Schulle.** 1981. Revealing the adhesion mechanism of cultured liver cells to glass surfaces during mitosis by reflection-contrast microscopy. *Zeiss-Inform. Oberkochen* 25: 41-43.
- Shotton, D.M.** 1988. Video-enhanced light microscopy and its applications in cell biology. *J. Cell Sci.* 89: 129-150.
- Taylor, D.L. and Y.-L Wang.** 1989. Fluorescence microscopy of living cells in culture. In *Fluorescent analogs, labeling cells and basic microscopy (part A) and Quantitative Fluorescence microscopy-imaging and spectroscopy; (part B).* *Methods in Cell Biol.* vol. 29 and 30.
- Taylor D.L., R. DeBiasio, G. LaRocca, D. Pane, P. Post, J. Colega, K. Giuliano, K. Burton, A. Gough, A. Dow, J. Yu, A.S. Waggoner, and D.L. Farkas.** 1994. Potential of machine-vision microscopy in toxicologic pathology. *Toxicol. Pathology.* 22: 145-159.
- Webb, W.W.** 1986. Light microscopy - A modern renaissance. *Ann. N.Y. Acad. Sci.* 483: 387-391.



Thermal Reference Images

The thermographic images on these pages represent the propagation of heat in micro-environmental systems. This enables you to visualize temperature distribution patterns normally not seen by the human eye. These images provide you with a far better understanding of what is happening on your stage than the limited information on the numerical displays of temperature controllers. The following thermographic images were acquired at the Bioptechs facility. They were made under laboratory conditions with the use of a calibrated thermographic camera. An infrared analysis program was used to extract the temperature data and annotate the images.

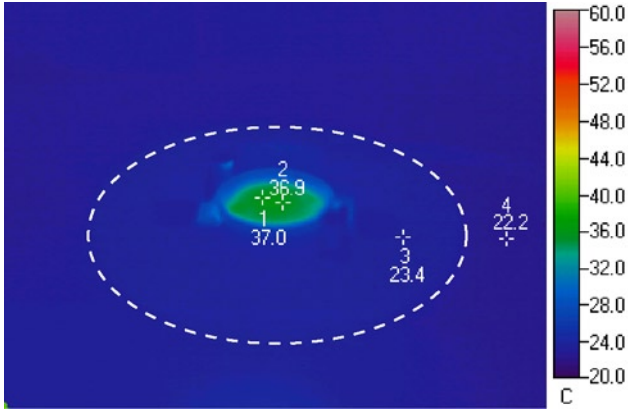

Thermal Profile of a Bioptechs Delta T Stage Adapter



Visible Light Image of a Bioptechs Delta T Stage Adapter

The first Thermograph shows the efficiency, accuracy and uniformity of the Delta T system. Notice the temperature of the stage adapter. It is nearly the same temperature as the room temperature background. Only the specimen and media are heated. Power consumption is 0.9 watts because heat is only applied to the specimen area. There is no heat transmitted to the stage. Therefore, it remains “Z” axis stable. This is a sharp contrast to traditional peripheral heating methods (shown below), and clearly superior.

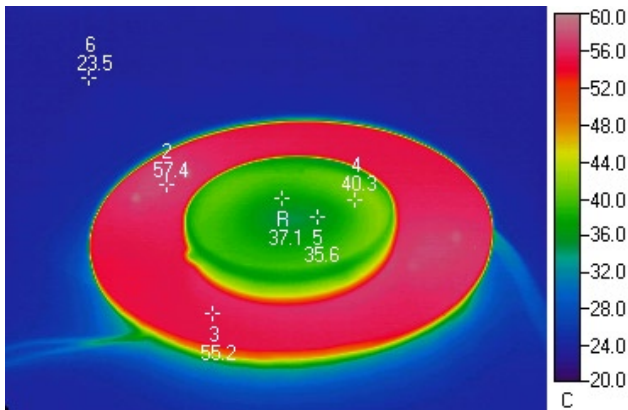

Thermal Profile of a Traditional Stage Heater

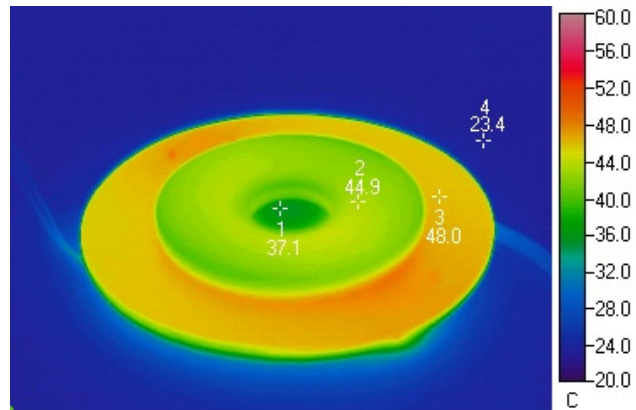

Thermal Profile of a Traditional Closed Chamber System

This thermograph indicates the disadvantage of peripheral heating. This is a thermal model of a 50mm culture dish in the center of a 100mm diameter uniformly heated, 3mm thick, aluminum plate with a 25 mm hole in the center. This image was acquired after 20 minutes of equilibration. Note the high temperatures of nearly 60 C, that it takes to reach 37 C in the specimen area. In this case heat that is not beneficial to the specimen is sunk into the stage causing Z-axis instability, not to mention the non-uniform temperature of the specimen area.

This thermograph shows a traditional geometry for a closed system chamber on a peripherally heated plate equilibrated for 30 minutes. There are two 40mm coverslips separated by a 0.5mm gasket sandwiched between a 100 mm heated aluminum plate and an acrylic ring cover. Note the temperature of the heated plate required to warm the center of the field. There is a two-degree difference between the center of field and the acrylic plate, a nine-degree difference between the heated plate and the specimen area. This plate is resting in free air, not in contact with a stage plate that would sink much of the heat away through conductivity. This excess heat transmitted to the microscope results in “Z” axis variations. Also, due to the poor thermal conductivity you can see that it would take a long time to re-equilibrate after perfusion.

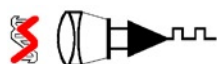

Thermal Reference Images

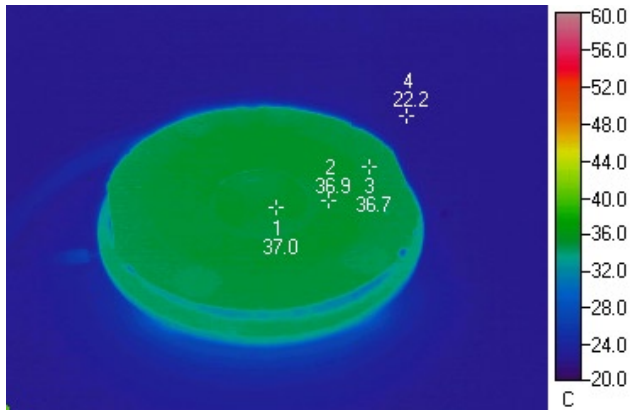

Thermal Profile of a Biopetechs FCS2

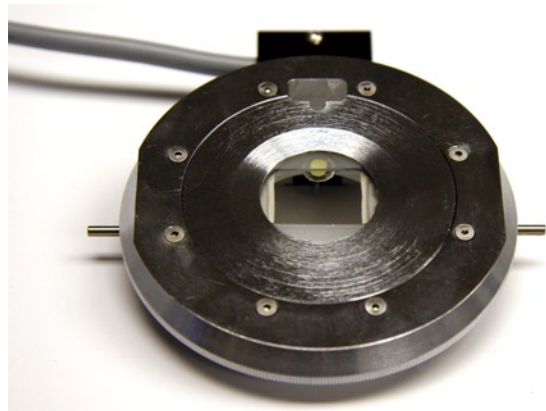

Visible Light Image of a Biopetechs FCS2

The thermograph above demonstrates the uniform temperature distribution of an FCS2. Notice that the coverslip temperature is so uniform that its location, in infrared, is indistinguishable from the base of the chamber. This demonstrates the effectiveness of the ITO heated Microaqueduct slide. It is capable of re-equilibrating cell temperature within seconds of perfusion and eliminates the typical thermal gradient that occurs with peripheral heating.

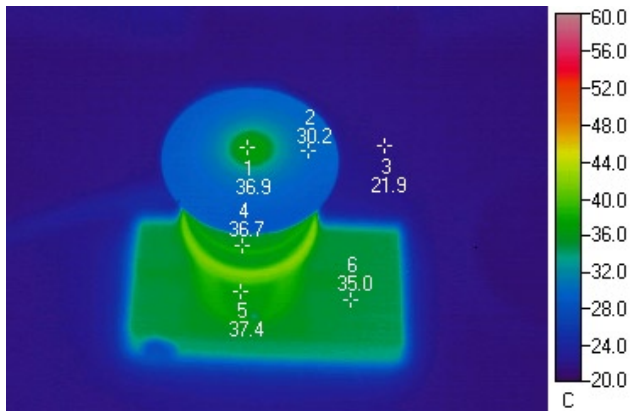

Thermal Profile of a Biopetechs Objective Heater



Visible Light Image of a Biopetechs Objective Heater

Notice the temperature distribution in the following locations: nosepiece, bottom of objective, region above heater band, and top of objective. Power consumption after equilibration is 1.3 watts. The point is that, unless you warm the entire microscope, the microscope will always act as a heat sink with respect to warming the objective. You can expect a small thermal gradient. All objectives have different thermal profiles. Therefore, it is imperative to efficiently transfer heat to the core of the objective and prevent excess heat from radiating from the heater-band. This is exactly what the Biopetechs Objective Heater does! Check with Biopetechs for thermal information on your objective.



Biotechs Stable "Z" Specimen Warming System

Not everyone needs the sophistication of a high-end Delta T Dish System, or the expense that comes with it. Therefore, Biotechs has developed a very competitively priced specimen warming system that accommodates any brand of 35mm dish and provides superior thermal control with the exclusive feature of "Z" axis stability for time-lapse applications. Examine the construction of the Stable "Z" and see for yourself how "stage warmers" should have been made from the beginning! If you need a specimen warmer or if you are still using a traditional "heated metal plate" to warm your specimen, contact Biotechs for a demo of this new technology! Introducing the Biotechs Stable "Z" Specimen Warming System

Adapter plate has a low thermal conductivity and near zero thermal expansion. This nearly eliminates heat transfer to the stage

Thermal expansion adjustment ring compensates for dish height

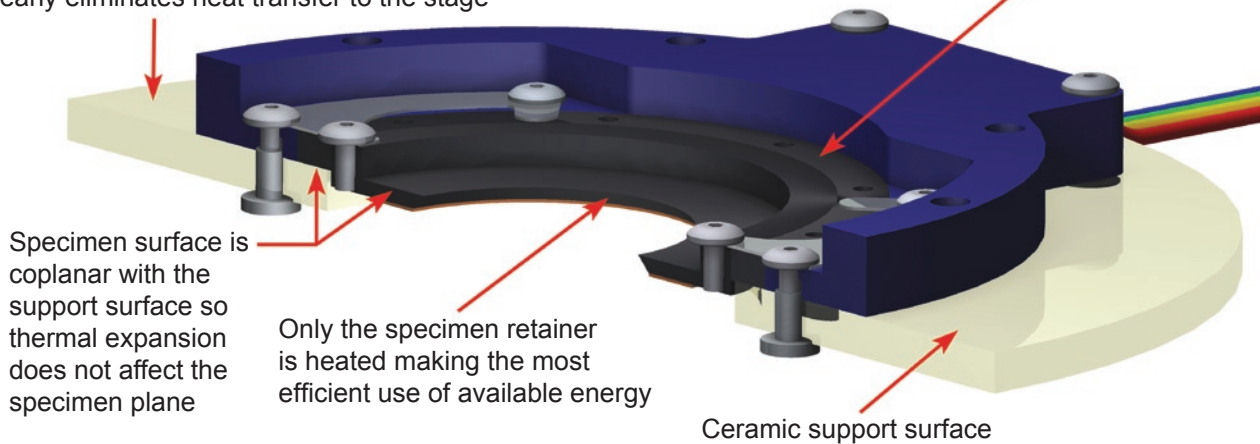

- Stage Geometry to Fit All Popular Microscopes
- Adjustable Compensation for Variations in Plastic Ware
- Small Footprint Controller; Easily Mounted on Scope
- Powered by 12 V AC Adapter or 12V Battery
- Can Accept Any Brand 35mm Dish

- Ambient to 50°C
- Only 4 Watts
- Includes Reference Sensor
- CE, UL, CSA, Certified
- Electrically Quiet

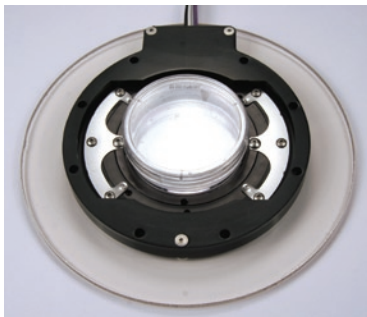

Olympus Stage Adapter

NEW!!!

Now available multi-well heater for Nunc Lab-Tek slides!

Magnetically held pressure piece that both holds the slide from moving during stage translation and transfers heat to surround the wells

Nunc Lab-Tek™ 1,2,4 and 8 well coverslip bottomed chamber slides

Z-axis stable heating plate

Ceramic support surface designed to fit into an SBS plate geometry

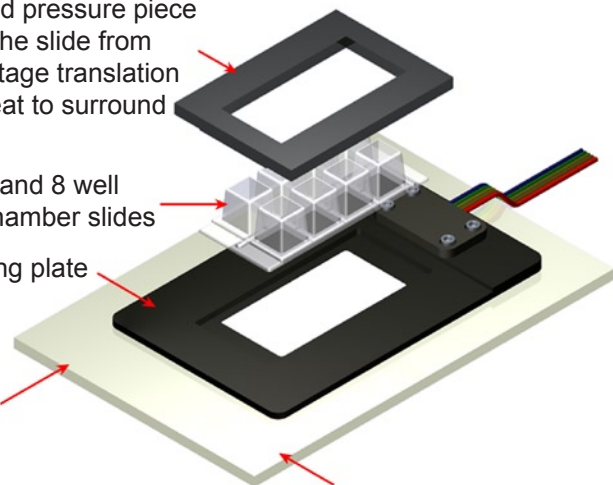

Adapter plate has low thermal conductivity and near zero thermal expansion this effectively eliminates heat transfer to the stage



Stable Z Controller



Introducing the Bioptechs Educational (EDU) Series Culture Dish Control System!

The Delta T EDU is a simplified version of the popular Delta T system that is typically used at the Ph.D. level. It is designed to enhance the instruction of biology by providing a standardized platform along with a set of instructions that make curriculum relevant demonstrations easy to do and provide a cost savings to the educational institution. The Delta T EDU gives students the opportunity to experience some of the excitement or wow factor of observing events that occur in Insect, Yeast, Mammalian, and Avian specimens at the cellular level. Some of the demonstrations that can be accomplished in one lab period are: yeast budding, bacterial invasion and replication, chemically induced reactions of cells, cell to cell interaction, chick embryo heart rate variations, etc. Bioptechs is currently looking to partner with educators to develop additional live cell demonstration protocols.

Contact Bioptechs if you would like to try a system or suggest a demonstration that you would like to be able to do in your classroom!

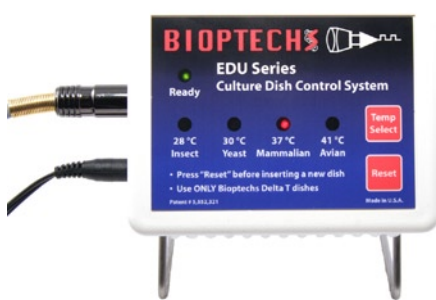

EDU Series Controller



EDU Stage Adapter



Thermal Slide Carrier

Introducing the Bioptechs Thermal Slide Carrier

The Thermal Slide Carrier provides the user with a simple, inexpensive yet accurate means of warming specimens on a microscope slide on an upright microscope. Simply slide the Bioptechs ITO coated slide into the carrier and place the carrier into any specimen holder of an upright microscope. A closed loop feedback controller reads the temperature of the upper surface of the glass slide and applies the appropriate current to the ITO coated underside of the slide to control temperature. Great for short term observation of live cells. Compatible with all modes of microscopy!

Revision 5 Bioptechs Controllers!

Bioptechs is pleased to introduce a new generation of temperature controllers with new features!

- Improved analog performance with full digital interface
- Greater ease of use, convenient desktop design
- Smaller footprint uses less desk space
- New **GREEN** design uses less power and operates more efficiently
- Operates from any 12VDC source



Delta T Rev 5 Controller



FCS2 & 3 Rev 5 Controller



Objective Heater Rev 5 Controller



Biotech's Open Dish Systems

An open dish should be used when you need to have physical access to cells or tissue for such applications as microinjection, electrostimulation, wounding, micromanipulation, use of mechanical probes, recording, and stimulation.

-or-

An open system may offer the most economical, convenient, and accurate micro-observation method for your application providing an open fluid surface is acceptable. The following section offers a variety of techniques and supportive equipment beneficial for the micro-observation of:

- Adherent cells
- Tissue cultures on a lattice
- Suspended cells
- Natural or artificial membranes

The Biotech's Delta T[®] Culture Dish System is an open dish live-cell environmental, optical containment system. It was designed specifically for live-cell micro-observation. Every aspect of its design was engineered for the safety of the cells and convenience of the user.



Delta T[®] is ideally suited for use on an inverted microscope even with high N.A. lenses.

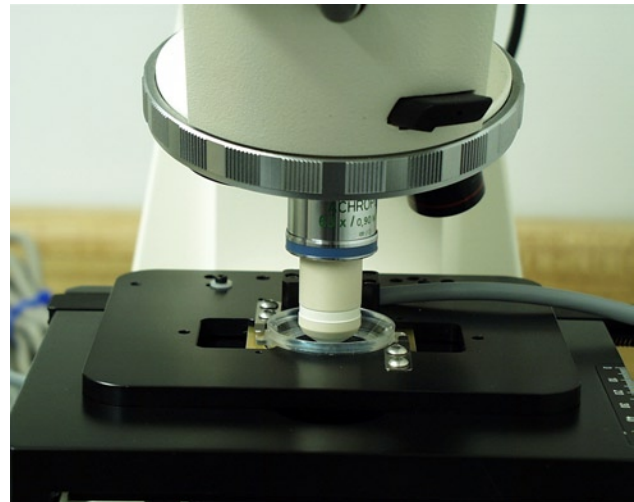

Delta T[®] compliments dipping lenses or LWD 10 - 63X lenses used on an upright microscope.

Stage heaters are a thing of the past. What you really want and need is fast, efficient specimen temperature control. Stage heating should be the last thing you want to do because it can cause Z axis drift. Biotech's introduced and established The Delta T[®] Culture Dish System with first-surface direct thermal transfer and dual mode temperature control for imaging applications in 1993. Biotech's has now integrated numerous customer requests into this current generation of Open Culture Dish Micro-Environmental Control System, the Delta T[®].

An easily applied continual perfusion system can be employed in either open or closed modes making long-term experiments routine and simplified.



Biotech's Delta T[®] Open Culture Dish System

Finally, a culture dish system specifically designed for live-cell microscopy! Now you can have accurate temperature control and high numeric aperture compatibility in a convenient disposable culture dish system compatible with all modes of microscopy. Never before has there been so many capabilities integrated into a specimen control system.

- Easily adapted to a variety of specimen types from monolayered adherent cells to tissue preps
- Low mass to thermo-regulate as opposed to conventional stage heaters
- Plate, incubate, and observe without the need to transfer your cells
- Fast thermal recovery after perfusion (within seconds)
- Compatible with inverted and upright microscope stands
- Coverglass bottom for optimum optical compatibility
- No need for warm air blowers or stage heaters
- Direct first-surface heating to your cells
- No preheating



Developed and manufactured by Biotech's, Inc. Pat No. 5,552,321

An intelligent feedback loop passes an electrical current through a thin film coating on the underside of the glass substrate on which the cells are grown. Heat is applied directly to the cells without the inefficiencies associated with peripheral heating by traditional culture dish warmers. The controller features a real-time temperature display and fast learning curve to compensate for cooling due to surface evaporation while responding to temperature changes due to perfusion. There is also an alarmed protection circuit to safeguard the cells and an internal reference for user adjustable calibration. The standard controller has a temperature range of ambient to 50°C. Biotech's exclusively offers opaque culture dishes which eliminates internal reflection of unwanted ambient light from the background for fluorescence imaging.

New Features Now Standard on all Delta T[®] Systems:

- Mode indicator (dynamic or imaging)
- Cold start acceleration
- Heat shock activation
- Remote setpoint port
- TTL interface and footswitch mode activation
- Temperature output port for recording
- Heated Lid power supply

You will find the Delta T[®] a reliable and indispensable addition to your microscope.



The Biotech's' Delta T[®] Culture Dish System makes traditional micro-environmental chambers obsolete!

Traditional Culture Dish Warming

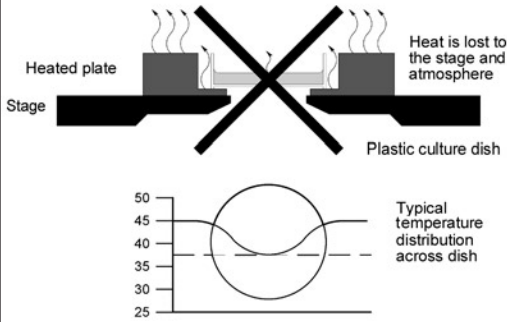

Limitations of Traditional Technique

- Stage heaters are inefficient, slow, and inaccurate
- Plastic dishes are poor conductors of heat
- Temperature does not recover quickly during or after perfusion.
- Plastic dishes are not suitable for high resolution or polarization microscopy
- Nonuniform temperature distribution
- Unnecessary dead volume
- Usable aperture of dish limited by the opening in heat transfer plate
- Surface evaporation significantly contributes to non-linearity of temperature distribution

Delta T Control

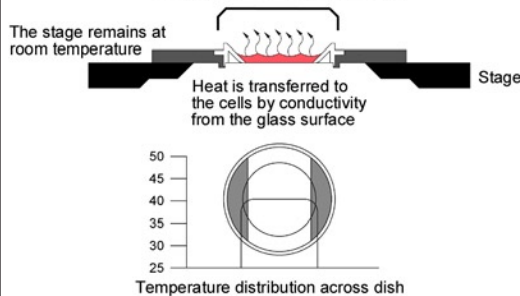

Advantages of the Delta T[®] Dish System

- Place cells onto coverglass and observe
- Highly accurate temperature control
- Fast thermal recovery
- Superior optical image
- Stage adapters to fit most popular microscopes
- Designed for inverted microscopes but ideal for water immersion objectives on uprights
- Immediate alarm if cell temperature changes
- Rigid mount for X, Y stability
- Uniform temperature distribution
- Cells unaffected by surface evaporation
- Numerous specimen adapters available

Exploded View of Delta T Culture Dish With Cover

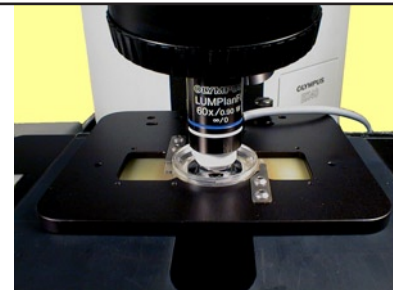
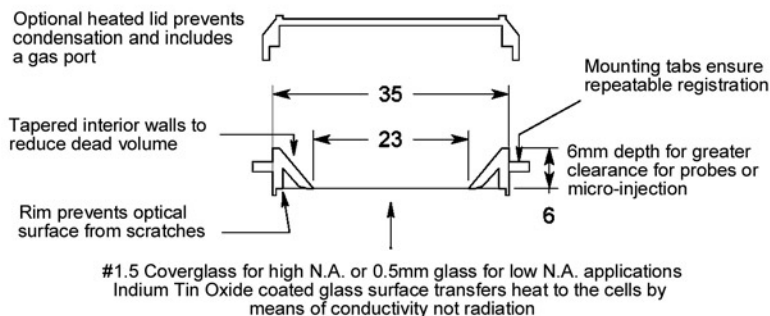

Originally designed for Inverted microscopes. However, when combined with water "dipping" objectives the Delta T is ideal on upright microscopes.

- Optional heated cover to prevent condensation from forming when used with transmitted modes of microscopy. Biotech's PN 04200803
- For low N.A., use a temperature controller, stage adapter, and a quantity of dishes are all you will need. However, for high N.A. compatibility, an Objective Heater and an Objective Temperature Controller must also be used to assure uniform temperature across the field.
- The Delta T controller operates from 100-240 volt AC, 50-60 Hz, or battery. Thermo-regulation is achieved through control of both amplitude and duration of the current flowing through the ITO coating; average power to dish is 0.9 Watt.

Biotech's also offers the Delta T[®] Dishes without the Indium Tin-Oxide coating for applications where temperature control is not required. These dishes are available upon special request at a much lower cost and are compatible with all of the accessories of the standard Delta T[®] Dish.



Delta T[®] Controller Included Features

Many of these features are made possible due to its fast thermal response which is not possible with conventional peripheral / radiant heating systems.

Revision 5 Controller

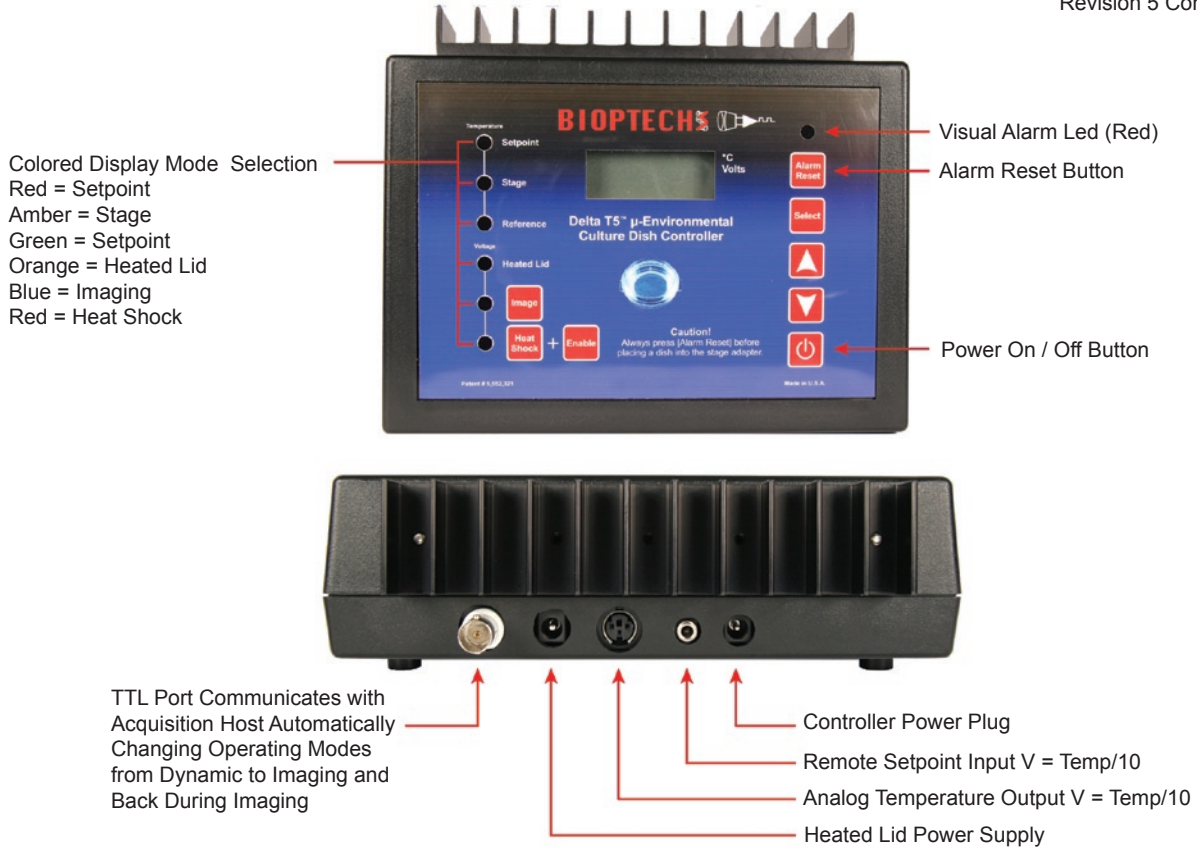

Options for the Delta T[®] Culture Dish System

Hinged Perfusion Adapter

The Bioptechs Hinged Perfusion Adapter provides Delta T[®] Culture Dish users with a convenient and inexpensive method of supporting perfusion needles in the culture dish. The typical application is to maintain low volume perfusion over cells during long-term experiments. Perfusion adapters are sold in pairs; one hinge and needle is used to irrigate, the other is used to aspirate. The balance between irrigating and aspirating can be maintained continuously with the use of the Delta T[®] Micro-Perfusion pump*. Additional supports can be added to hold gas jets, pH probes, cooling apparatus, or other items which do not require critical positioning.



Bioptechs PN 0420081601

Benefits

- Needles compatible with 1/16" tubing
- User adjustable friction for reliable positioning
- Repeatable positioning, flips out when replacing dishes
- Adjustable pick-up tube to control level of media in dish
- Perfusion assembly translates with the dish & stage adapter
- Eliminates the need for expensive micro-manipulators for low precision positioning

* Bioptechs recommends the use of the Micro-Perfusion Pump with the double tubing set for closely regulated micro-perfusion.

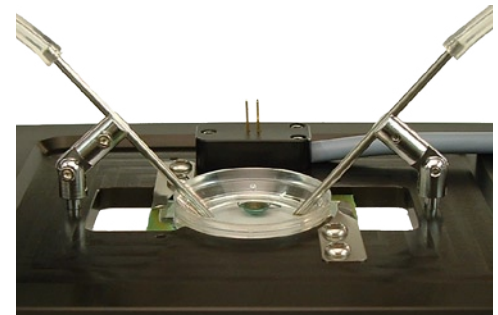

Options Continued

Coverglass Lid

The Coverglass Lid is a cover for the Delta T[®] Culture Dish to be used when imaging to create an optical surface onto the liquid in the dish. This eliminates the optical effect of fluid motion at the air to liquid surface above the cells that causes the contrast of the image to change. Therefore, when acquiring a series of images in a transmitted light, contrast enhancing mode of microscopy all images will have a uniform contrast.

Forming an optically flattened glass-to-media surface on the top of the cells eliminates this problem. The Coverglass Lid fits loosely on the Delta T[®] Culture Dish and supports a 1 mm x 22 mm coverglass in the center of the field 3mm above the specimen. The Coverglass Lid is reusable and helps the Delta T[®] bridge the gap between an open dish and a closed system environment. The Coverglass Lid is made of 304 stainless steel, autoclaveable, and available with or without perfusion. This item and/or the Heating Culture Dish Cover are nearly essential for multi-user facilities.

Perfusable

Non-perfusable

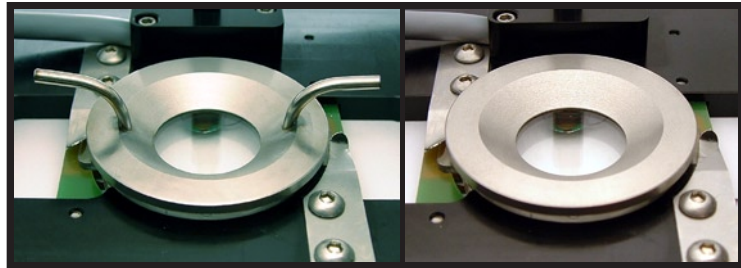

Biotech PN 0420031216

Biotech PN 04200312

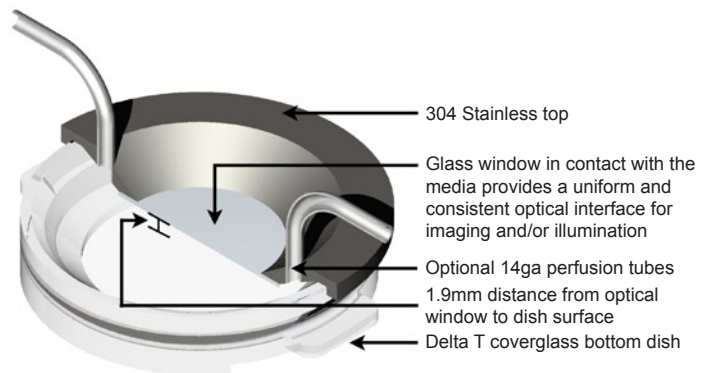

Heating Culture Dish Cover

The Biotech Heating Culture Dish Cover is a device, which provides a condensate-free optical surface above the media in a Delta T[®] Culture Dish through which specimens can be transilluminated on an inverted microscope. It is autoclaveable and powered by the Delta T[®] Controller. The Heated Lid also provides a gas port to enable containment and control of atmospheric conditions under the lid.

The Biotech Heated Lid with Perfusion is a device, which will provide a condensate free optical surface on the top of a Delta T[®] Dish through which specimens can be perfused and trans-illuminated on an inverted microscope. Specimens can be perfused by attaching perfusion tubing to the ports provided. It is recommended to use the Biotech Micro-Perfusion Pump with the dual perfusion tubing for this purpose.



Biotech PN 04200803

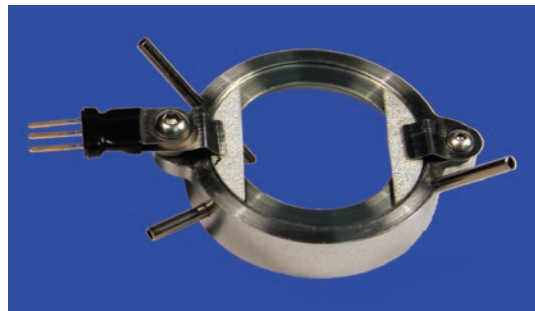

Biotech PN 0420080316

The Heating Culture Dish Cover is made of 316L stainless steel and glass with gold contacts. It is reusable, autoclaveable, and an ideal accessory for multi-user facilities.



Options Continued

Delta T® Cooling Ring

The Biotech's Cooling Ring is an immersion device that absorbs heat from the specimen by providing a thermally conductive physical barrier between chilled fluid passing through the ring and the fluid surrounding the specimen. This Cooling Ring is made of autoclavable 304 stainless steel and provides the microscopist with a convenient and inexpensive method of reducing the temperature of specimens in Delta T® Culture Dishes. The Cooling Ring is supported on the stage adapter and translates along with the dish. It is easily flipped out of the way to enable easy exchange of dishes in the stage adapter. It is ideal for temporarily cooling the specimen during micro-injection.

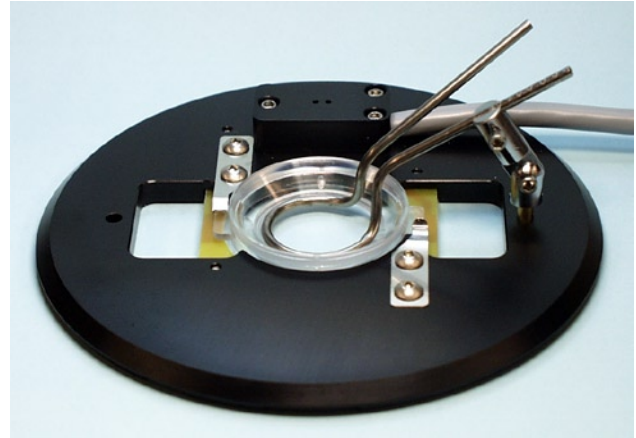

Biotech's PN 04200318

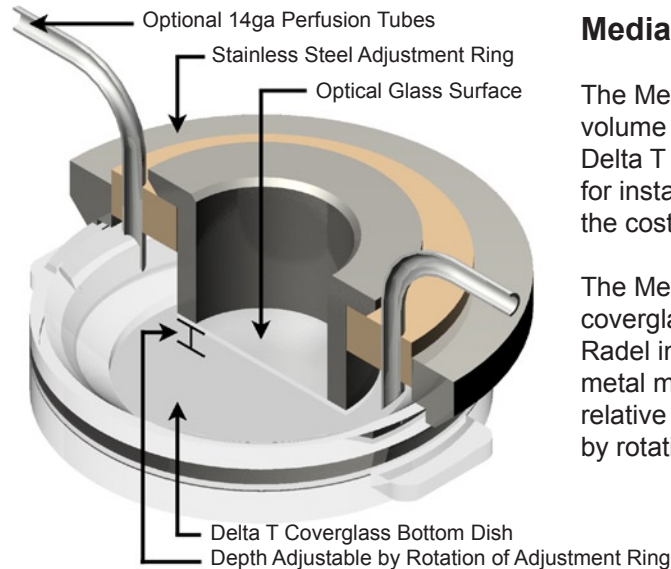

Media Volume Reducer

The Media Depth Reducer allows for the reduction of media volume above cells adherent to the coverslip bottom of a Delta T Dish. Reducing this volume may be desirable when, for instance, background fluorescence is a problem, or when the cost of a reagent dictates the use of small volumes.

The Media Depth Reducer is composed of a 1mm thick coverglass window mounted in an externally threaded black Radel insert, which in turn mates to an internally threaded metal mounting ring. The height of the coverglass window relative to the coverglass bottom is continuously adjustable by rotating the Radel insert.

Biotech's PN 04200303

Yeast Slide

The Biotech's Yeast Slide provides an optically transparent, temperature controlled surface on which to place specimens on an upright microscope. It is a glass slide with an ITO coating on its bottom surface measuring 50mm X 75mm. It is placed on the stage of an upright microscope and mechanically constrained by conventional means. It accommodates a standard 25 x 75mm slide having yeast or other specimens under a coverslip. Its temperature is maintained by an electronic controller that reads temperature from the slides integral thermal sensor and heats by passing a current through the ITO coating on the underside of the slide.

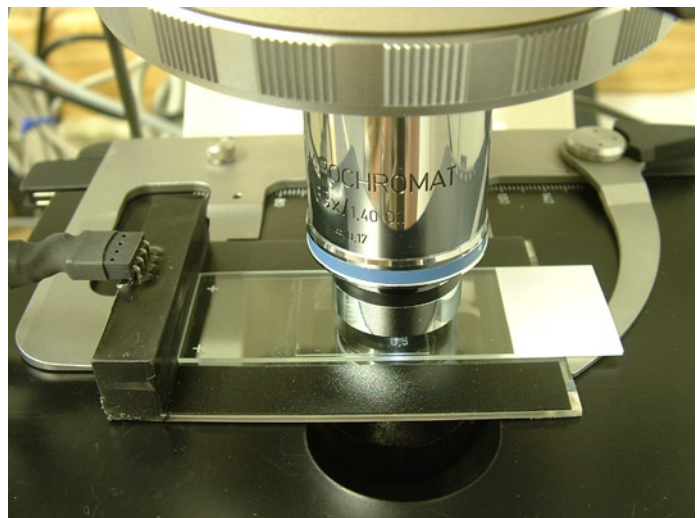

Biotech's PN 042005076



Tissue Slice or Artificial Membrane Micro-Observation Utilizing Delta T® Culture Dish System

The Biopetechs Delta T® Culture Dish System gives you a great deal of flexibility never before achievable with traditional culture dishes. To observe a specimen, you only have to place it in the Delta T dish within the focal plane of the objective and let the Delta T® system maintain the temperature, optical, and fluid requirements. Biopetechs manufactures several adapters to provide a convenient method of micro-observation of live tissue or cells grown on artificial membrane. Refer to the diagrams below for samples of the devices currently available or consider the advantages of combining one of the traditional inserts available from Costar, Falcon, Nunc, etc. with the Delta T® Culture Dish System.

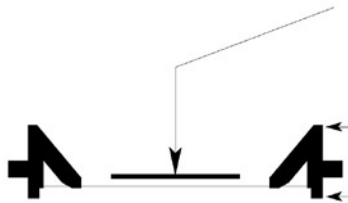

Specimens are defined onto a plane parallel to the coverslip for flat-field observation and suspended in the dish by a Radel holder threaded into an adjustment ring.

Both the upper and lower contact surfaces of the dish are precision injection molded to be used as optical reference planes.

Tissue Slice Adapter for Delta T Culture Dish System

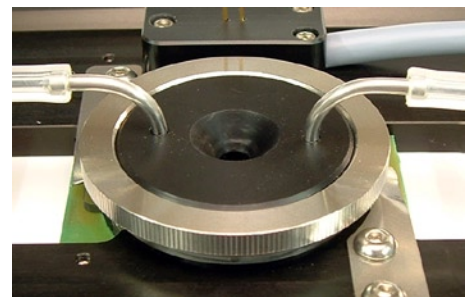
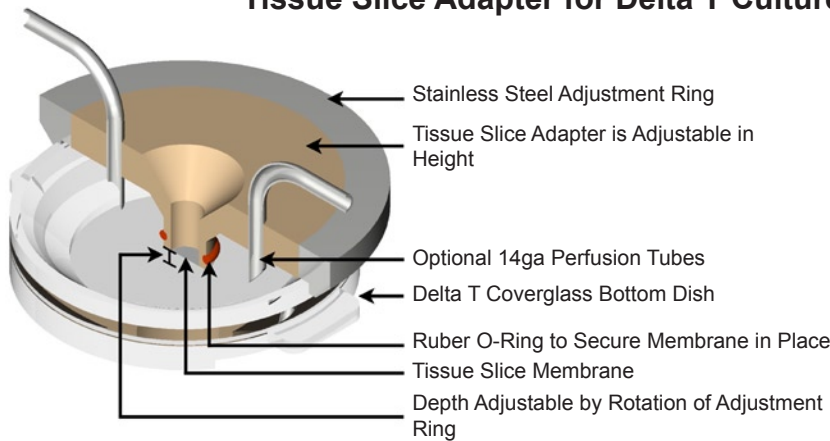

Biopetechs PN 042021918

Membrane Insert Adapter for Delta T Dishes

The Delta T environment is easily adapted to accommodate many of the artificial membrane culturing products on the market. The device shown supports a Costar Transwell membrane. The bottom surface of the membrane is observable on an inverted microscope and adjustable in the "Z" axis to enable accommodation of higher numeric aperture lenses. Perfusion ports can be used to perfuse the basal surface of the specimen. Both surfaces of the membrane can be perfused separately.

- Tubing connections 1/16"
- Fits only Delta T Dishes
- Reusable
- Autoclaveable
- When ordering this device, Biopetechs requires a sample of the insert to be used.



Biopetechs PN 0420011301



Brain Slice Micro-Observation Chamber for Inverted Microscopy

The Biotech's Brain Slice Adapter is combined with the Delta T® Culture Dish System to provide a convenient method of observing thick cut sections of brain or other tissue in a perfusable, temperature controlled, optical environment on an inverted microscope. Perfusion ports are made of 304 stainless steel and are compatible with 1/16" tubing. As with all Biotech's Delta T® Culture Dish Adapters, the specimen is adjustable in the Z axis plane to accommodate the working distance of the objective. Custom geometry adapters are available upon special order to accommodate specimens having unique geometry.

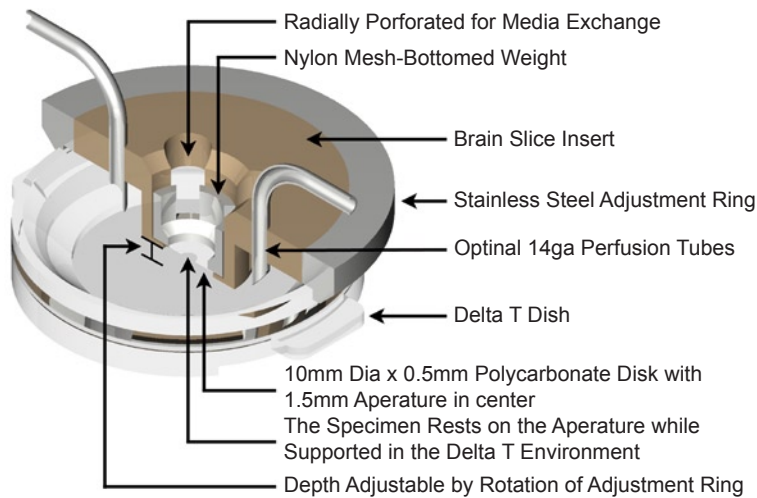

Biotech's PN 0420201919

- The specimen is placed onto a polycarbonate disk with an aperture in its center
- This disk is placed into a well / receiver in the Z adjustable support
- A 304 stainless steel weight with a Nylon mesh covering rests on the specimen to keep it from floating
- This assembly is threaded into a focusing ring that rests on the top of the Delta T Dish
- The depth of the specimen in the dish is adjusted by rotating the focusing ring
- Perfusion occurs around all surfaces of the specimen

Atmospheric Barrier Ring For Water “Dipping” Objectives on Upright Microscopes

The Atmospheric Barrier Ring is made of borosilicate glass, autoclaveable and available in several sizes to fit most popular water “dipping” lenses. It is placed around the barrel of water “dipping” lenses on upright microscopes to reduce ambient contamination and evaporation, thereby increasing humidity above the specimen and helping to retain the pH during long-term time lapse imaging.

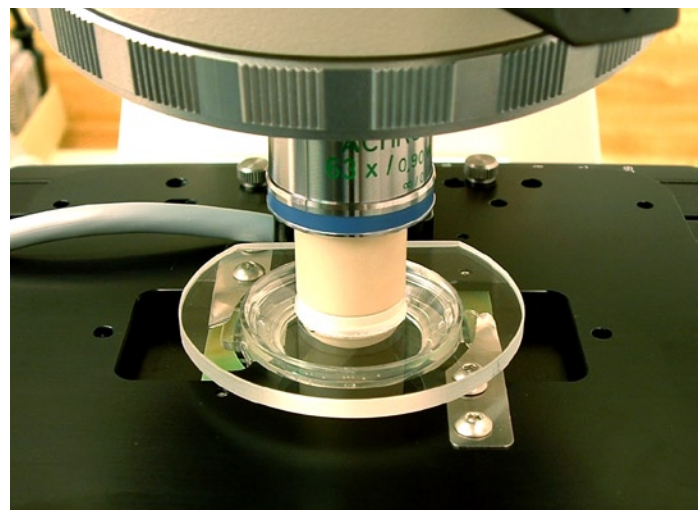

Biotech's PN 04200325



Automated Perfusion Configuration for Delta T™ Culture Dish System

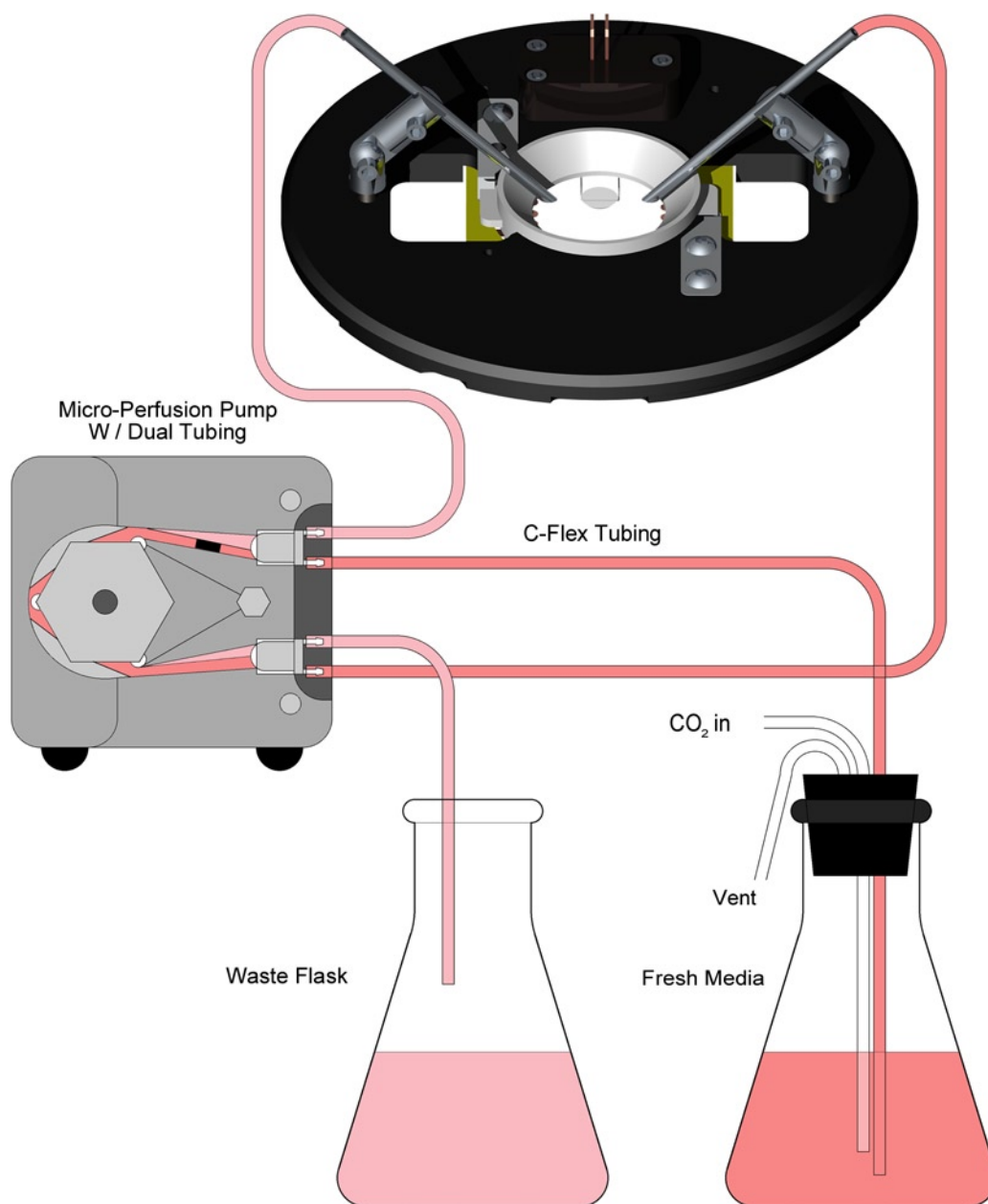

The Delta T Micro-Perfusion Pump is equipped with a dual tube manifold. The tube with a black ring on it has a slower fluid transfer rate than the other tube. The fresh media supply is coupled to this slow flow tube and the dish aspiration needle is attached to the faster flow tube. The level in the dish is controlled by adjusting the depth of the aspiration needle. This technique works well with all Delta T perfusable accessories.

Note: The Hinged Perfusion Adapters (shown) can be replaced by the Perfusable Coverglass Lid for closed system perfusion.



Bioprotechs Delta T System Media Perfusion Diagram with CO₂ Regulated Media

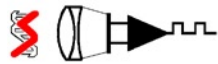
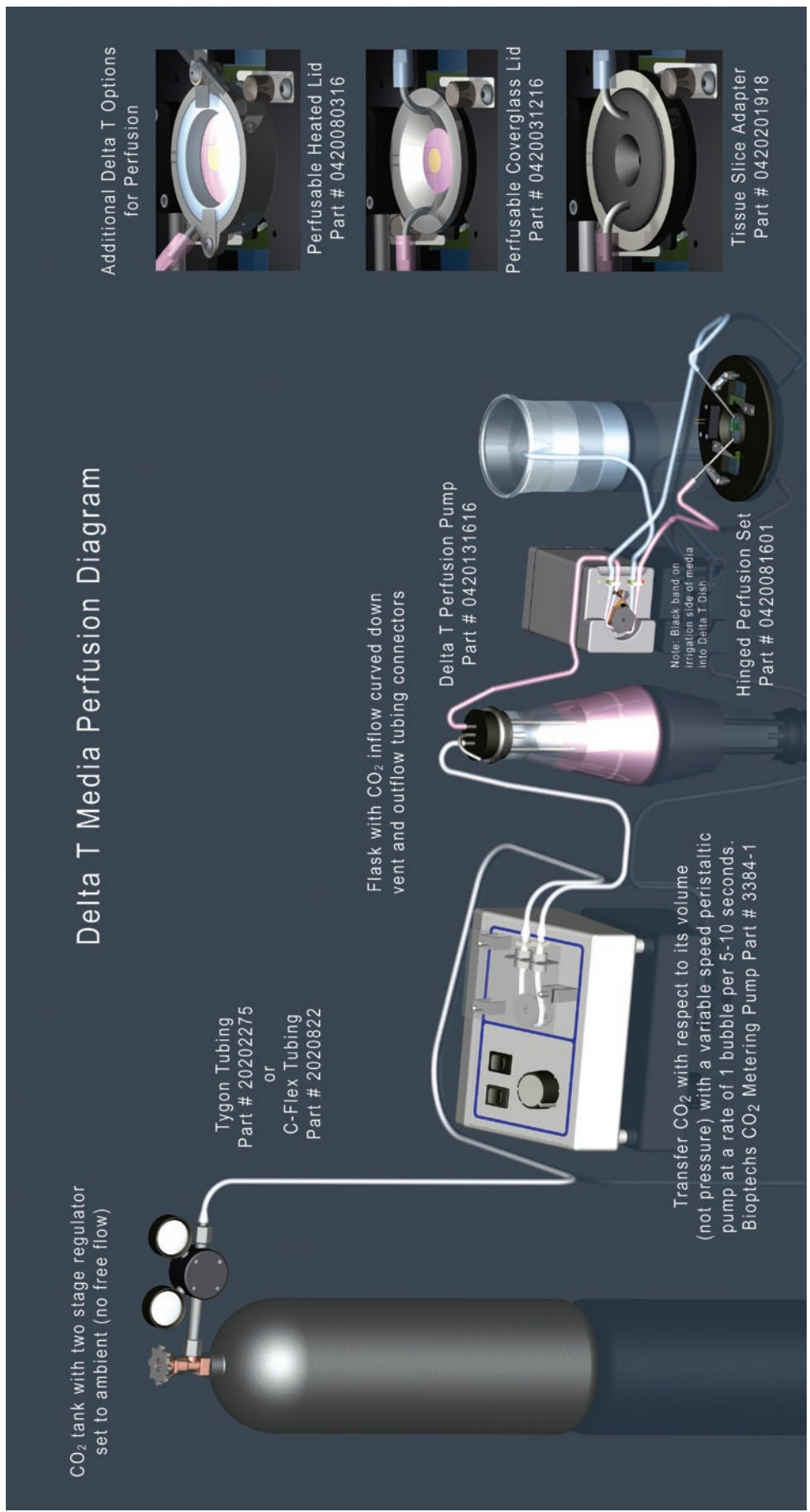

Bioprotechs Delta T System with CO₂ Perfusion Above the Media Diagram

Heated Lid CO₂ Perfusion Diagram

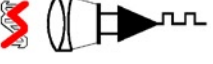

Biotech's Delta T[®] Stage adapters

The Biotech's ΔT° Stage Adapter reads the temperature of ΔT Culture Dish, provides electrical contacts to power the dish, and supports the dish on the stage for translation. All ΔT systems require a Stage Adapter. These images are provided to assist in identifying and selecting a stage adapter appropriate for your microscope.

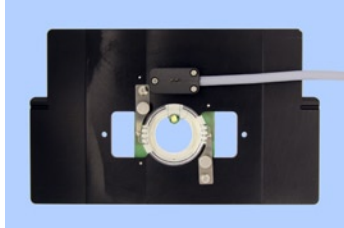

Single plate stage adapter fits:
Zeiss Axioverts
Leica DMIRB
Biotech's PN 04202601

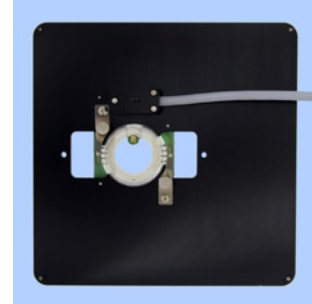

Leica DMIRB triple plate stage adapter
Biotech's PN 04201203

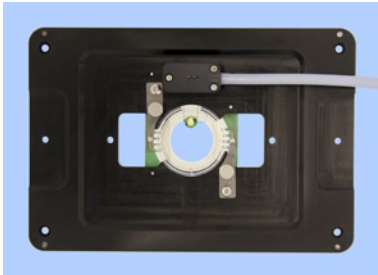

Triple plate stage adapter fits:
Axiovert, Ludl, Prior, and ASI
stages
Biotech's PN 04202602

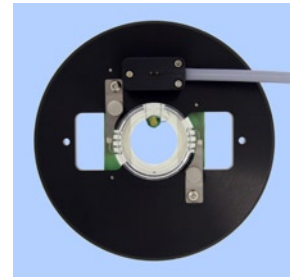

Round stage adapter fits: Nikon, Olympus,
and Delta Vision stage openings
Biotech's PN 04201415
To fit Zeiss Gliding stage PN 04202603

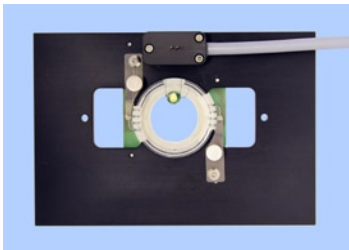

Multi-well plate size adapter fits
into any multi-well receiver
Biotech's PN 04202003
Cell Robotics size PN 04201220

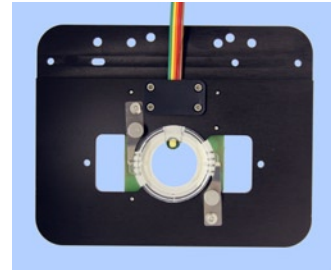

Delta T Upright stage adapter fits
most upright microscopes
Biotech's PN 04202116

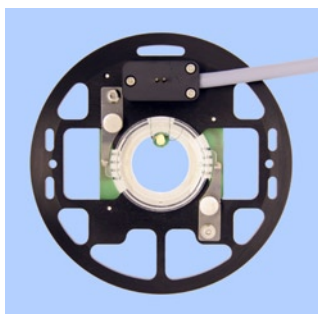

Leica Galvanic round stage insert
Biotech's PN 04201207

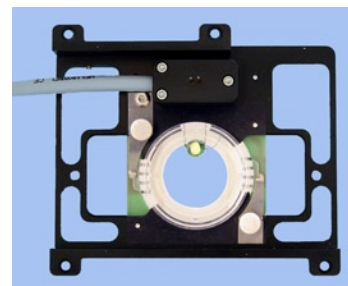

Leica Galvanic rectangular stage insert
Biotech's PN 04201807
Marzhauser Galvanic rectangular stage insert
Biotech's PN 04202807



Accessories

Biotech's Culturing Cylinders:

Culturing Cylinders are used to barricade cells or suspended specimens in a Delta T® Culture Dish or to restrict and concentrate the growth and location of cells plated on an FCS2® Coverslip. They are 5mm high and available in a variety of inside diameters including 1mm, 2mm, 4mm, 6mm, 8mm, 10mm, and 12mm. The outer diameter is always 2mm greater than the inside diameter due to the 1mm wall thickness. The cylinders are made of Pyrex glass and are heavier than plastic cloning rings to eliminate floating. They are optically polished on the bottom surface to mate with and form a tight seal with other glass surfaces such as FCS2® Coverslips and Delta T® Culture Dishes without the need of grease. Culturing Cylinders can be autoclaved for reuse.

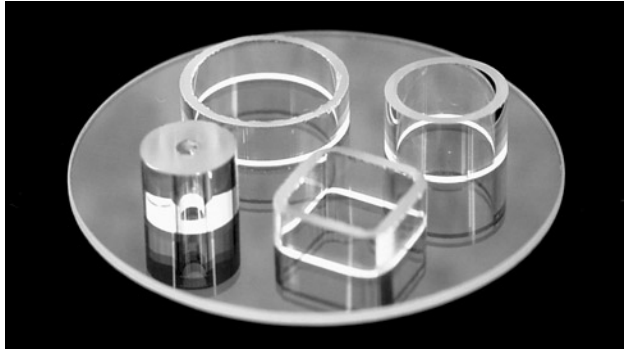

See Price List for Biotech's PN

No grease, no contamination, reusable!

Delta T® Culture Dish Application:

When using Culturing Cylinders with the Delta T® Culture Dish, select the appropriate size cylinder for the protocol and place the cylinder into the center of the dish. Pipette the specimen into the cylinder. Then pipette media around the cylinder to a depth equal to the depth in the cylinder, thereby equalizing hydrostatic forces.



FCS2® Application:

Place the appropriate Culture Cylinder onto the center of the 40mm FCS2® Coverslip to restrict plating of the cells to the central region of the Coverslip. Apply media around the cylinder to equalize hydrostatic forces. After cells have grown to confluence, remove the Culture Cylinder and transfer the coverslip to the FCS2® for micro-observation.



Boekel Desktop Warmer

When working with live cells on a microscope, it is convenient to have an incubator close to the scope. It is beneficial for temporary storage of chambers as well as specimens or media to keep them prewarmed. Most importantly it is a clean, dry, and safe place for objectives when not being used. Biotech's recommends the Boekel Warmer because of its small size and light weight. It is not humidified, making it an ideal warmed objective storage device. The Warmer measures 8" x 8" x 7", operates on 120V AC, and is small enough to be mounted close to the microscope for temperature controlled storage of perfusion media during experiments.

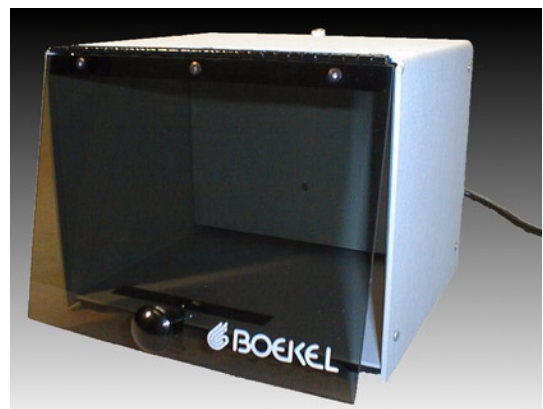

Biotech's PN 260700



Biotechs Closed Chamber Systems

Closed systems are used for the following applications:

- The experiment requires that the specimen be contained in a completely airtight environment.
- The optical constraints of the microscope dictate a more precise definition of optical surfaces.
- The experiment requires discrete control of the flow characteristics (shear-force issues).

Biotechs offers an advanced common sense approach to live-cell environmental control. The FCS2® Closed System along with the Objective Heater® for high numeric aperture applications is the most reliable and easily modifiable method for time-lapse micro-observation of living cells available.

Eliminates the need for:

- Warm air curtains (blow dryers)
- Heat lamps
- Peripheral stage warmers
- Microscope enclosures

The following section offers an integrated solution for closed-system, micro-environmental control complete with near laminar perfusion, user definable volume and flow, and optical compatibility with all modes of light microscopy.

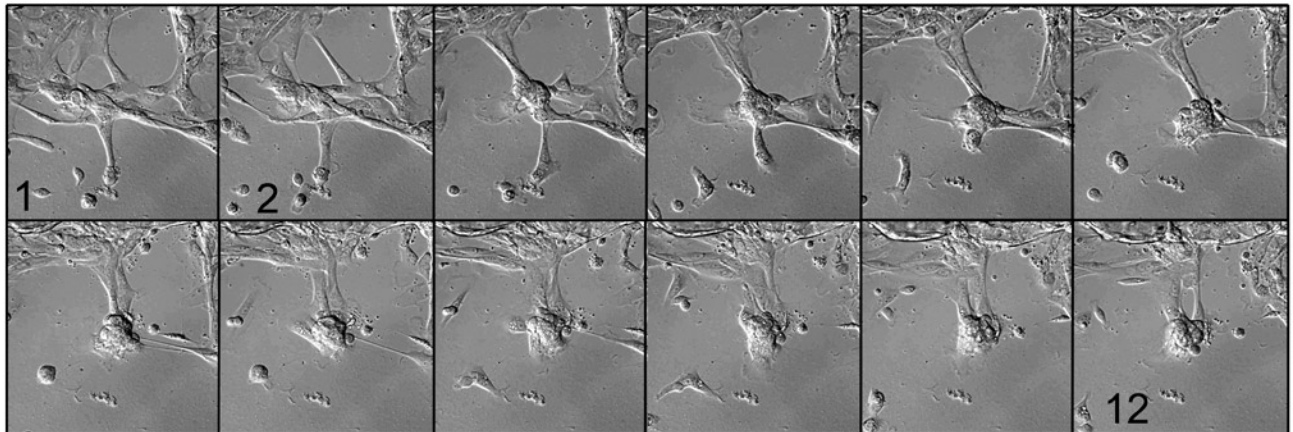

Eight-hour time lapse of normal mammary epithelial cells at 250X DIC. Mammosphere formation is visible in this video. (The round cluster of cells in the center of the field is a mammosphere.)
Compliments of Jean Latimer Ph.D. Magee Womens Research Institute, Pittsburgh, PA.

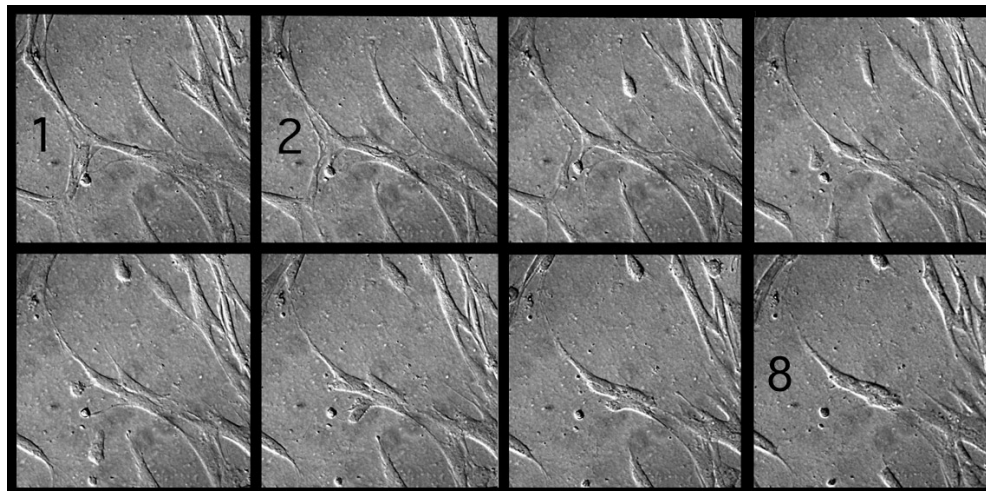

Tissue: Human Breast Tumor Cells

Total acquisition Time: over 5 hours (1 frame every 10 minutes)

8 pane image represents 1 frame every 30 minutes

200X DIC Zeiss Axiovert, QED Imaging, **Biotechs FCS2® Chamber System**

Image compliments of Jean Latimer, Ph.D., Magee Womens Research Institute, Pittsburgh, PA



In order to accurately record the morphology of your cells, you will need a micro observation environment that is both conducive to their viability and compatible with all techniques of microscopy!

The Bioptechs' Focht Chamber System (FCS2®) is a state-of-the-art, parallel plate flow cell with uniform temperature control and a user definable flow cavity that is compatible with all modes of light microscopy including: BF, DF, PH, DIC, Hoffman, Fluorescence, Confocal, and Multi Photon.



Developed and manufactured by Bioptechs, Inc. patent #s 4974952, 5414556 and 5410429

- Microaqueduct design enables proper Koehler illumination with high numeric aperture optics for both transmitted and reflected modes of microscopy
- Suitable for no flow through high flow rate procedures where a rapid exchange of media is required and discrete control of cell surface shear is user definable
- Cell temperature can be controlled from ambient to 50°C ± 0.1°C without the need of an air curtain
- Temperature is controlled uniformly across entire field with media equilibrating as it enters the chamber
- Compatible with 1/16" tubing for perfusion
- Easily assembled with ordinary skill (no tools required)
- Stand-alone temperature controller with an alarm interrupt circuit to safeguard your cells
- Objective Heater® and Objective Temperature Controller required for high N.A. applications
- Remote setpoint interface and/or chart recorder output now included on all systems
- Closed system so that CO₂ dependent media can be employed



Biotech's FCS2® Technical Data

The patented FCS2® Microaqueduct Slide technology, with its heated optical thin film coating, provides high numeric aperture compatibility, temperature control without an air curtain, high volume perfusion rates, user definable volume, and control of cell surface shear. The optical design of the FCS2® is based on slide and coverslip geometry to provide compatibility with all microscopy techniques.

Specifications:

Physical size	75mm OD, 13mm high	Maximum volume exchange rate	1/sec
Coverslip #1.5 thick X	40mm Diameter	Minimum fluid aperture	0.63mm ²
Imaging aperture	22mm	Separation between optical surfaces	50 - 1000µ
Maximum volume	0.706µL	External port ID	1.6mm
Minimum volume	0.043µL	Temperature stability	±0.1°C

The controller features separate channels for the microaqueduct slide and metal chamber base plus:

- Large backlit LCD temperature display
- Logic circuit safeguards cells
- Built in calibration
- Audible and visible LED alarm
- Chart recorder output for temperature recording
- Remote setpoint for temperature programming
- Auto reset
- Dual voltage operation 120 - 240V AC 50 - 60 Hz

The volume of the chamber is determined by both the thickness and internal geometry of the lower gasket. The flow characteristics can be further modified by changing the internal geometry of this gasket. An assortment of gaskets shapes and thicknesses as well as blank gasket material is included in the starter kit.

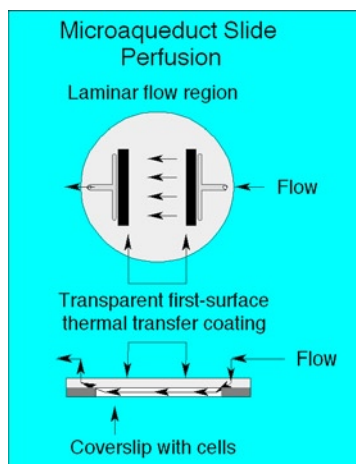

The FCS2 Starter Kit Includes

Chamber, Controller, 5 Microaqueduct slides, 30 piece gasket set, 50 - #1.5 coverslips. The Objective Heater and Objective Heater Controller is optional (needed for use of high numeric aperture objectives).

The objective heater is mounted to the upper end of the central retracting tube of the objective. The standard size fits diameters between 17 and 28mm. The medium size fits diameters between 23 and 29mm. There is also a large size to fit objectives with 26 - 35mm diameter.

Biotech's PN 060319-2-03 (FCS2 Chamber)

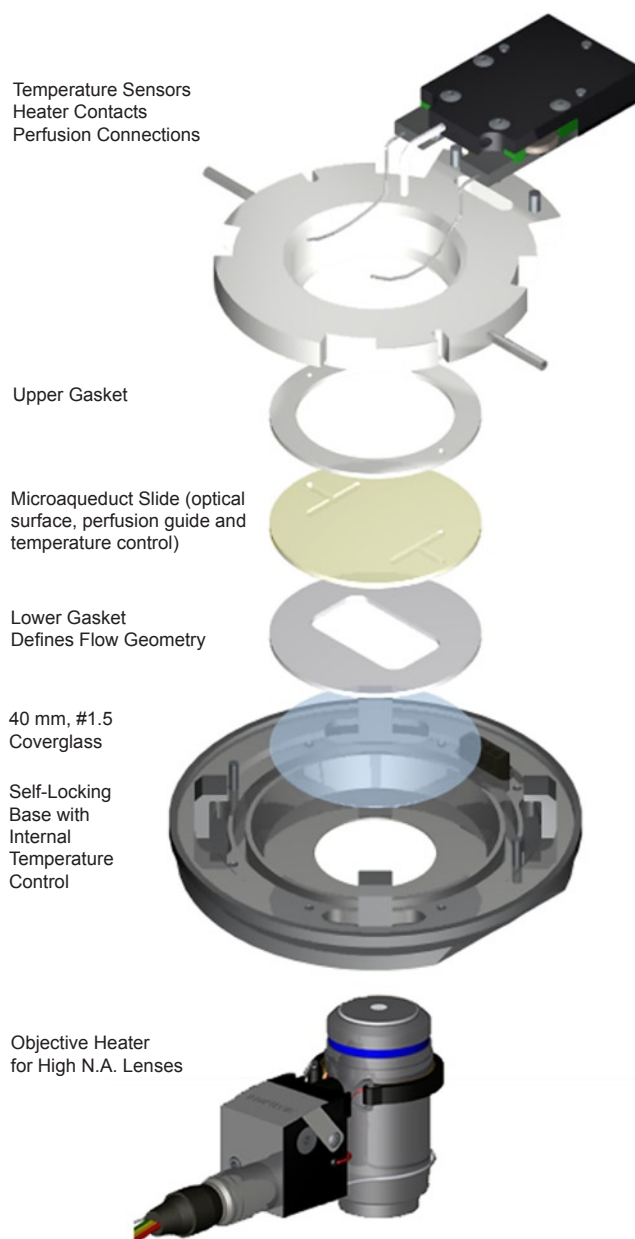

Typical FCS2® Perfusion Configuration for Induced Change Experiments

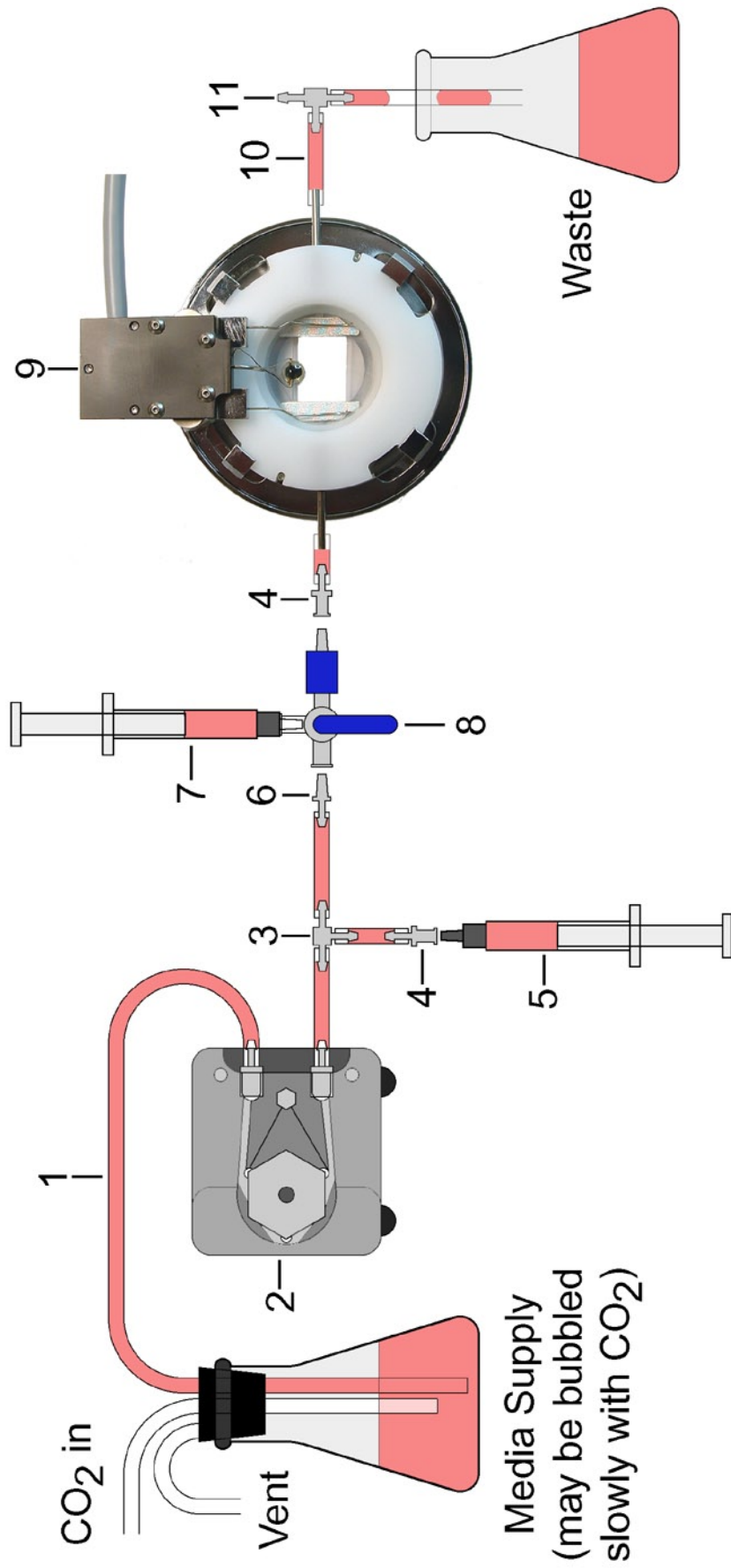

- 1 Perfusion tubing, 1/16" ID supply line (keep as short as possible)
- 2 FCS2 Micro-Perfusion Pump (recommended for prolonged, controlled perfusion in delicate optical cavities)
- 3 Tee adapter (adds low volume syringe to facilitate manual perfusion when loading chamber)
- 4 Luer adapter (female, adapts Luer taper syringe to 1/16" tubing)
- 5 Low volume glass syringe

- 6 Luer adapter (male, adapts 1/16" tubing to female Luer lock)
- 7 Alternate media glass syringe (growth factors, inhibitors, etc.)
- 8 Three-way valve (switches source of perfusion; pump or manual)
- 9 FCS2 Chamber
- 10 Tubing to waste container
- 11 Tee adapter (place at same height as chamber, open top of tee to prevent siphoning)

Note: Syringes are glass to prevent contamination of media from silicone lubricant typical in plastic syringes.

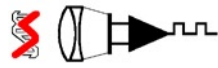

CO₂ Enriched Media Schematic for Biopetechs FCS2 & FCS3 systems. Easy to setup, reliable and consumes very little CO₂

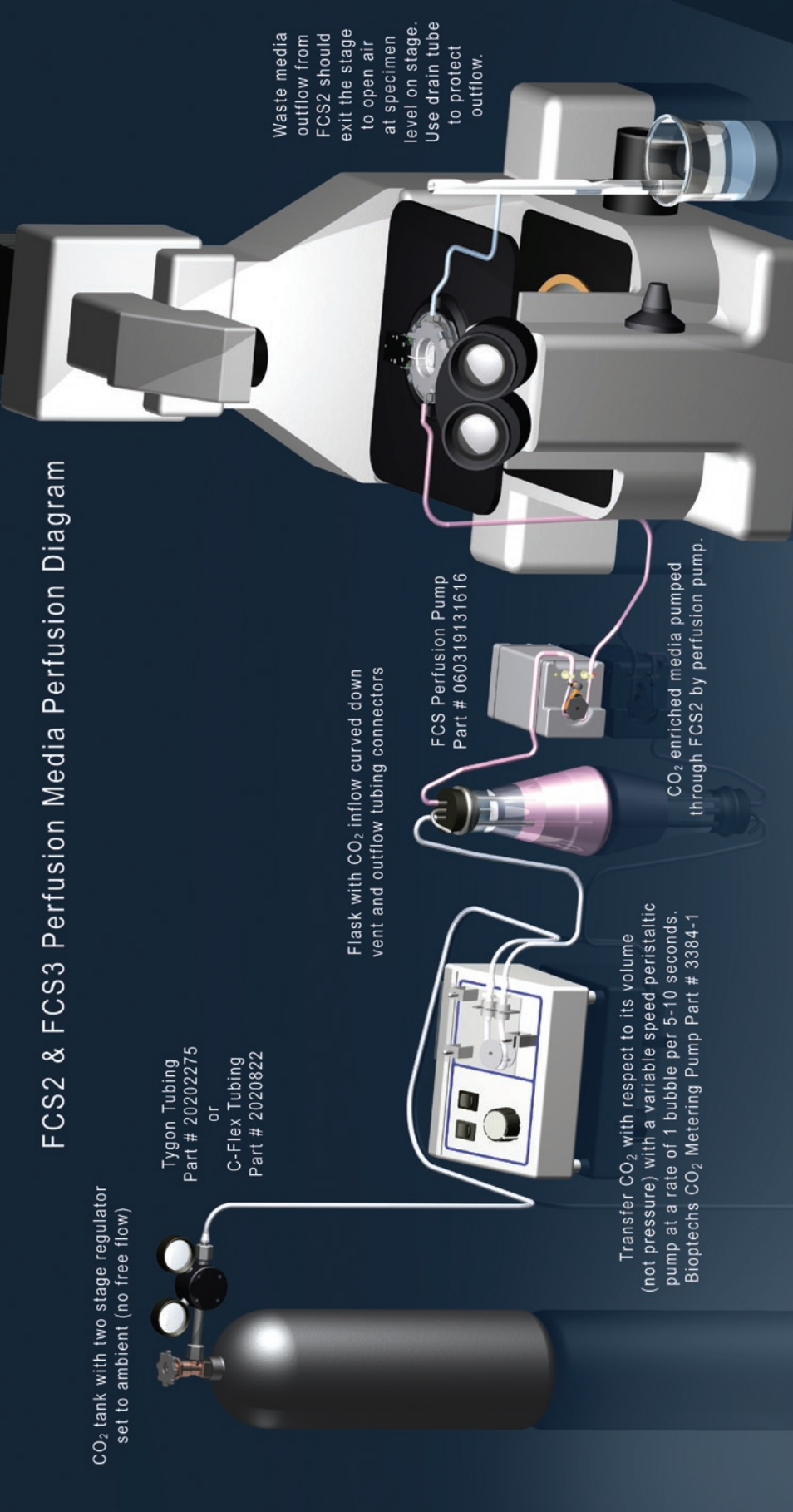

Biotechs Options for the FCS2®

Open Mode Top for the FCS2®

The open mode option allows the FCS2® to be assembled without the microaqueeduct slide thus exposing the cells on the coverslip for microinjection. The coverslip can then be removed and reassembled with the microaqueeduct slide for long term time-lapse applications.



Biotechs PN 060319-2-1513

Open Mode Adapter

Installed on FCS2 Base

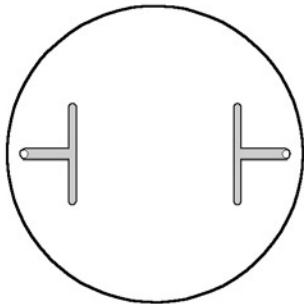

Biotechs PN 130119-5



Call for Biotechs PN

Custom Microaqueeduct Slides

The standard Microaqueeduct Slide is made with two “T” shaped grooves 22mm apart in a pattern optimized for uniform perfusion. If an experiment requires a narrow flow path or low dead volume, Biotechs can custom machine the microaqueeduct slide to your specifications.

Custom Gaskets

The standard gasket set included in the FCS2® Starter Kit contains gaskets of various thickness (ranging from 100 to 1000 microns) and internal geometry. Included are blank gaskets that can be customized by the end-user. However, in some cases an end-user may want a supply of a special shape or thickness of gasket. The Biotechs Custom Design Department can make these special items. We require a one-time setup charge in order to make any number of gaskets an end-user wants at the standard gasket price. Standard Gasket Set Includes: (3) 0.1mm 30mm Round, (2) 0.1mm 14 x 24, (3) 0.25mm 30 mm Round, (2) 0.25mm 14 x 24, (1) 0.25mm Blank, (3) 0.5mm 30mm Round, (2) 0.5mm 14 x 24, (2) 0.5mm Blank, (5) 0.75mm 30mm Round w/ holes, (2) 0.75mm 14 x 24, (1) 0.75mm Blank, (2) 1.0mm 30mm Round, (1) 1.0mm 14 x 24, (1) 1.0mm Blank

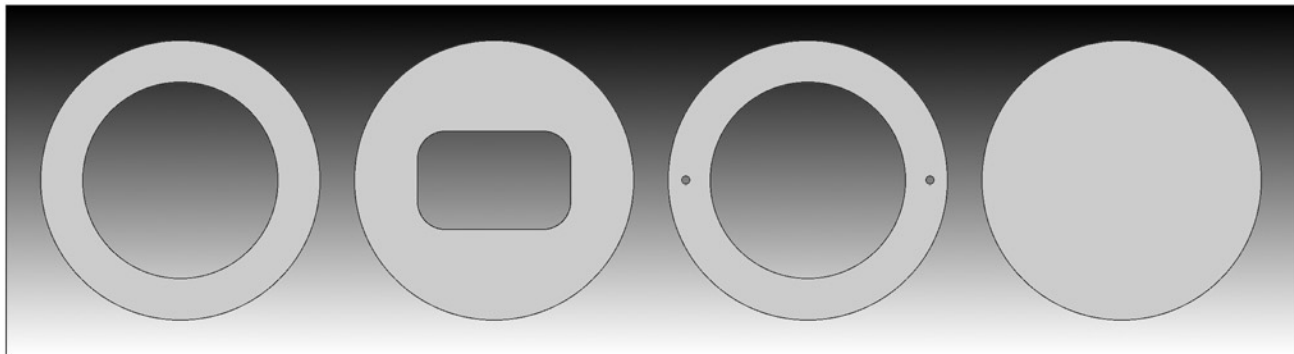

30mm Standard Round

14mm x 24mm Rectangle

30mm Round w/ perfusion holes

Blank 40mm

Tubing Adapters

Connecting tubing to syringes and chambers may require special adapters. Biotechs has assembled a kit of connectors and adapters which conform to the specifications in the FCS2® perfusion drawing (previous page). The kit components are pictured.

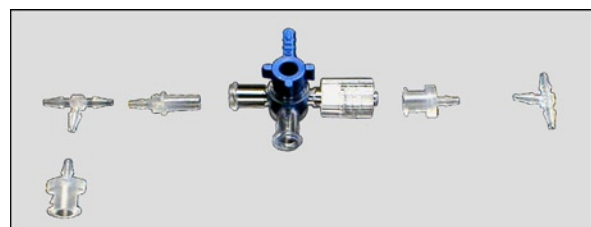

Biotechs PN 162003-1

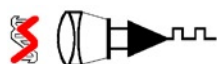

Closed-System Cooled Chamber

FCS2® Cooling

FCS2 Cooling Adapter

This configuration is designed to allow high N.A. observation of specimens at below ambient temperatures on an inverted microscope. This design provides the same optical and flow characteristics as the warmed FCS2

but provides an adjacent secondary perfusion chamber through which a refrigerant fluid is circulated. Caution: When working below ambient temperatures with high numeric aperture lenses, an Objective Cooling Ring and Objective Thermal Isolator should be used.

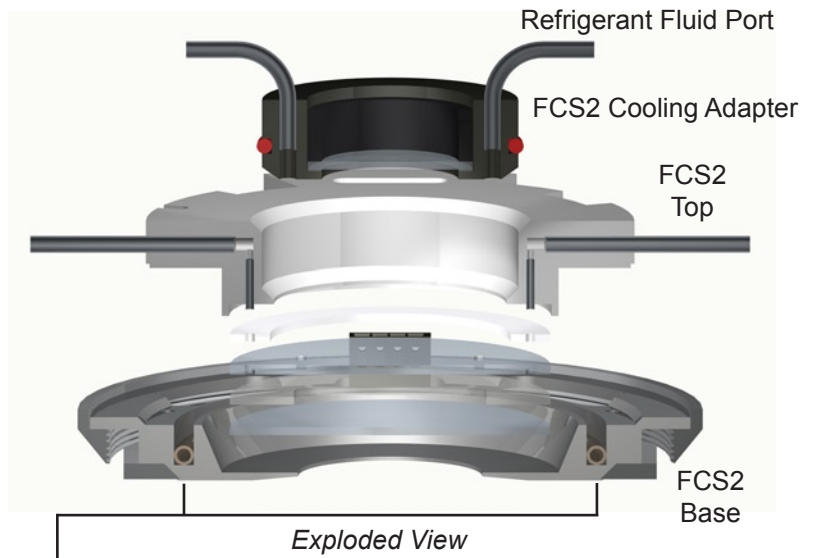

Note: optional tubing can be installed through which refrigerant fluid can be circulated. The coolant connection tubes exit the FCS2® from above. As shown in the picture below.

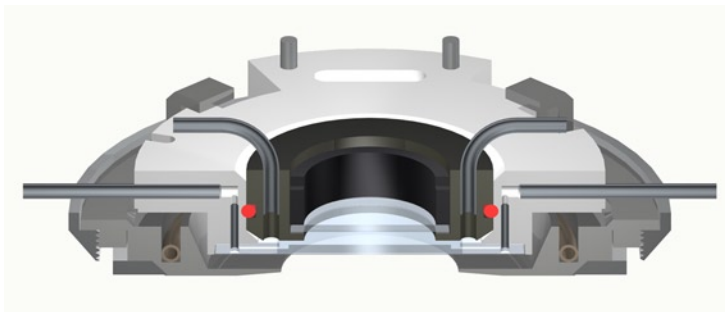

Assembled Cooled FCS2 With Cooling Adapter
Biopetechs PN 03060319-2

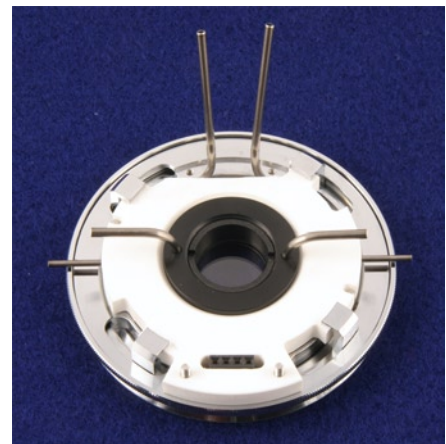

FCS2 with Cooling Adapter installed
Note: auxiliary tubing on the adapter

Biopetechs PN 03060319-2
(Cooling Adapter Only: 060319-2-0301)

How it works:

Cells are plated onto a 40 mm coverslip. Then the coverslip is placed into a modified FCS2® chamber. This provides a perfuseable laminar flow optical chamber with user modifiable flow characteristics. The upper glass element (microaqueduct slide) is then used to remove heat from the specimen cavity to be absorbed by the cooled fluid being circulated in the second, parallel cavity formed by the addition of an o-ring sealed window adapter. Gravity or an electric pump is then used to create a flow of chilled fluid through the heat exchange cavity in the chamber. The cells remain safely enclosed in a separate optical enclosure. If more thermal transfer is necessary, tubing can be installed into the base of the FCS2®.

Note: If you are using high N.A. objectives at below ambient temperatures, it will be necessary to cool and thermally isolate the objective from the microscope. The optional thermal isolator will prevent condensation from forming on the lower element of the objective. Four gas ports are provided to purge the adapter with dry air. An anti-reflection coated window optimized for 340-700 nm seals the bottom of the adapter. See page 40.



Biotechs FCS2® Stage Adapter Identification

The FCS2® Starter Set requires a stage adapter for precise positioning. Due to the diversity of microscope stages, a stage adapter cannot be included with the FCS2® Starter Set. Therefore, you need to select a stage adapter for your scope from the illustrations below. When ordering, please indicate the brand of microscope, the manufacturer's stage identification number, and description, along with the corresponding Biotechs' part number. Custom designs are available upon special order.



Round stage adapter fits:
Olympus IMT2, IX70, IX50
Nikon Diaphot, TE200-300
and Deltavision
Biotechs PN 060319-2-1415



Triple plate stage adapter fits only:
Leica DMIRB
Biotechs PN 060319-2-12

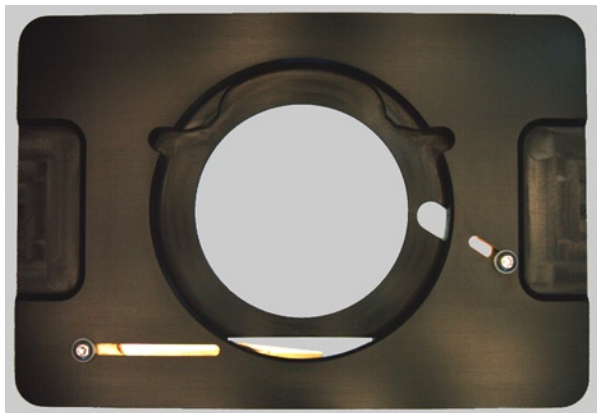

Triple plate stage adapter fits:
Zeiss Axiovert, Ludl, Prior, and ASI Stages
Biotechs PN 060319-2-2611

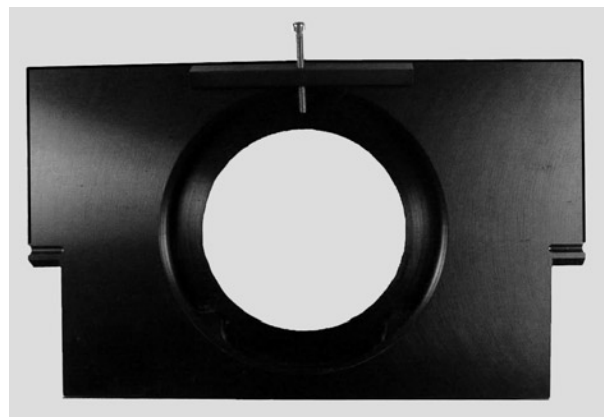

Single plate stage adapter fits:
Zeiss AxiovertI, Leica DMIRB and DMIL
Biotechs PN 060319-2-2613



Biotech's Upright Microscope Compatible Closed Chamber System (FCS3®)

The Biotech's **Focht Chamber System 3 (FCS3®)** is basically a redesign of the popular FCS2 but optimized for use on an upright microscope. The FCS3® uses the same, microaqueduct slide, gaskets, and, coverslips as the inverted model. Therefore, it has all of the same operating characteristics as its predecessor. The main difference, in the upright version, is that the coverslip portion of the optical cavity is oriented upward toward the objective*. As an added benefit, the upright version uses a universal stage adapter to fit all upright microscopes. By simply replacing the specimen carrier with the upright FCS3® interface plate, any upright microscope can become a multi-functional live-cell workstation.

The Upright FCS3® provides all the functionality of the inverted model (FCS2®) including:

- Microaqueduct design enables proper Koehler illumination with high numeric aperture optics for both transmitted and reflected modes of microscopy
- Suitable for no flow, through high flow rate procedures where a rapid exchange of media is required and discrete control of cell surface shear is adjustable
- Cell temperature can be controlled from ambient to $50^{\circ}\text{C} \pm 0.1^{\circ}\text{C}$ without the need for an air curtain
- Temperature is controlled uniformly across entire field with media equilibrating as it enters the chamber
- Closed system so that CO_2 dependent media can be employed
- Compatible with 1/16" tubing for perfusion
- Easily assembled with ordinary skill (no tools required)
- A stand-alone temperature controller with an audible alarm and interrupt circuit to safeguard your cells
- Objective Heater and Objective Temperature Controller required for high numeric aperture applications
- Includes the capability to interface to a computer for temperature programming and/or chart recorder output
- Fits most Leica, Nikon, Olympus & Zeiss upright microscopes (custom stage adaptors available)



FCS3 & Universal Upright Stage Adapter

The optical cavities supportive structure positions the microaqueduct slide 5mm millimeters above the stage surface with the coverslip facing upwards towards the objective. The additional space between the top surface of the stage and bottom of the microaqueduct slide is required for electronic connections and perfusion ports. It may be necessary, on some scopes, to readjust the condenser stop screw to accommodate this additional distance. No other modifications should be necessary.



Bioptechs FCS3®

Temperature Control:

The FCS3 was designed to maintain accurate thermal control and allow near laminar flow perfusion. Both of these functions are incorporated into our patented Microaqueduct Slide (see drawing below). The surface of the slide, opposite the specimen side, is coated with an electrically conductive transparent thin film of Indium-Tin Oxide (ITO) and two electrical contacts (busbars). When the FCS3 is completely assembled and placed on the stage adapter, two electrical contacts and a thermal sensor, (not shown in drawing), rest on these busbars. A temperature controller is used to pass a regulated current flow through the ITO Coating. This causes the surface of the slide to heat. The heat is transferred through the media to the cell surface on the coverslip thereby providing a conductive heat transfer. The metal base of the chamber is also temperature regulated to provide heat to both the incoming media and peripheral thermal support to the metal housing.

Microaqueduct Perfusion:

A fluid pathway is formed by separating the Microaqueduct slide from the coverslip containing cells with a single silicone gasket. This gasket can be any thickness from 50 micron to 1mm and any lateral geometry you choose or create. This arrangement allows the user to define the flow characteristics. Therefore, you are not limited by the geometry of the optical cavity instead you select or create it! Fluid access to this flow channel is made through two 14-gauge needle stock tubes protruding from the sides of the chamber top. These tubes provide fluid connection to two perfusion holes in the Microaqueduct slide that interface two "T" shaped grooves cut into the inner surface of the Microaqueduct slide. The "T" groove allows the media to seek the path of least resistance and become nearly laminar before flowing across the cells. This technique eliminates the need for the metal perfusion ring and additional gaskets, which are the limiting factors, required by most conventional chambers.

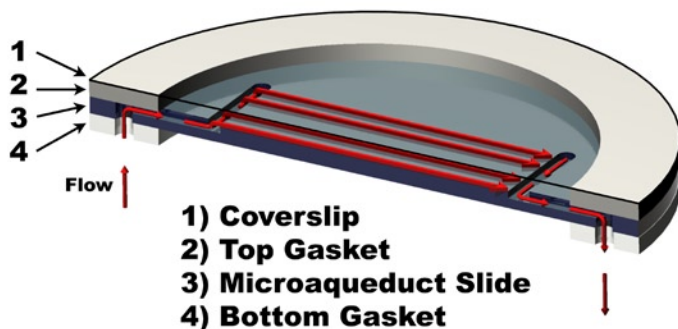

Microaqueduct Slide Perfusion Laminar Flow Region (Designated by Arrows)

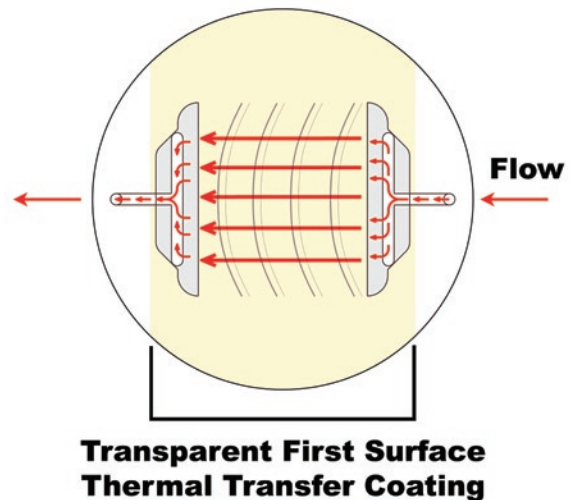

Microaqueduct design enables proper Koehler illumination with high-numeric aperture optics for both transmitted and reflected modes of microscopy

- Suitable for no flow through high rate flow procedures where a rapid exchange of media is required with low cell surface shear
- Cell temperature can be controlled from ambient to 50 degrees C +/- 0.2 degrees C without the need of an air curtain
- Temperature is controlled uniformly across entire field with media equilibrating as it enters the chamber
- Closed system so that bicarbonate CO₂ or organic buffers can be employed
- Compatible with 1/16" tubing for perfusion (C-Flex, Tygon, etc.)
- Easily assembled with ordinary skill (no tools required)
- Stand-alone temperature controller with an alarm circuit to safeguard your cells
- Near laminar flow

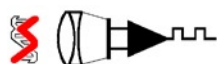

Biotech's FCS3[®] Technical Data

The FCS3[®] utilizes a patented Microaqueduct Slide technology, having an electrically conductive, optically transparent thin film coating, on its outer surface to provide the following attributes:

- High numeric aperture compatibility
- High or low rate perfusion capability
- Compatibility with all modes of microscopy
- Temperature control without an air curtain
- User definable volume, and control of cell surface shear

Specifications:

Physical size	75mm OD, 13mm high	Maximum volume exchange rate	1/sec
Coverslip #1.5 thick	40mm Diameter	Minimum fluid aperture	0.63mm ²
Imaging aperture	28mm	Separation between optical surfaces	50 - 1000μ
Maximum volume	706μL	External port ID	1.6mm
Minimum volume	43μL	Temperature stability	+0.1°C

The controller features separate channels for the microaqueduct slide and metal chamber base plus:

- Separate channels for the microaqueduct slide and chamber base
- Large backlit LCD temperature display
- Logic circuit safeguards cells
- Built in calibration
- Audible and visible LED alarm
- Chart recorder output for temperature recording
- Remote setpoint for temperature programming
- Auto reset
- Dual voltage operation 120 - 240V AC 50 - 60 Hz

*The volume of the chamber is determined by both the thickness and internal geometry of the upper gasket. Changing the internal geometry of this gasket can further modify the flow characteristics.

Easy Assembly No Tools Needed!

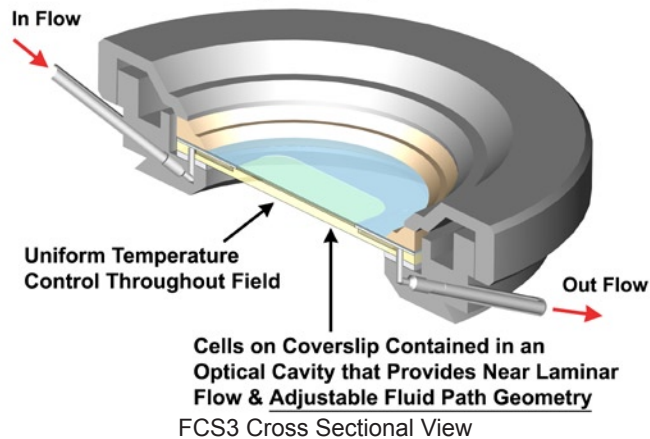

The FCS3 Starter Kit Includes

Universal upright stage adapter plate, Chamber, Controller, 5 Microaqueduct slides, a 30 piece gasket set including an assortment of various shapes and thicknesses as well as blank gasket material for user customization, and 50 - #1.5 40mm coverslips.

An Objective Heater and Controller are optional (needed for use with high numeric aperture objectives). The objective heater is mounted to the upper end of the central retracting tube of the objective. The standard size fits diameters between 17 and 28mm. The medium size fits diameters between 23 and 29mm. There is also a large size to fit objectives with 26 - 35mm diameter. (See page 43)

Biotech's PN 21-060319-3-03 (FCS3 Chamber)

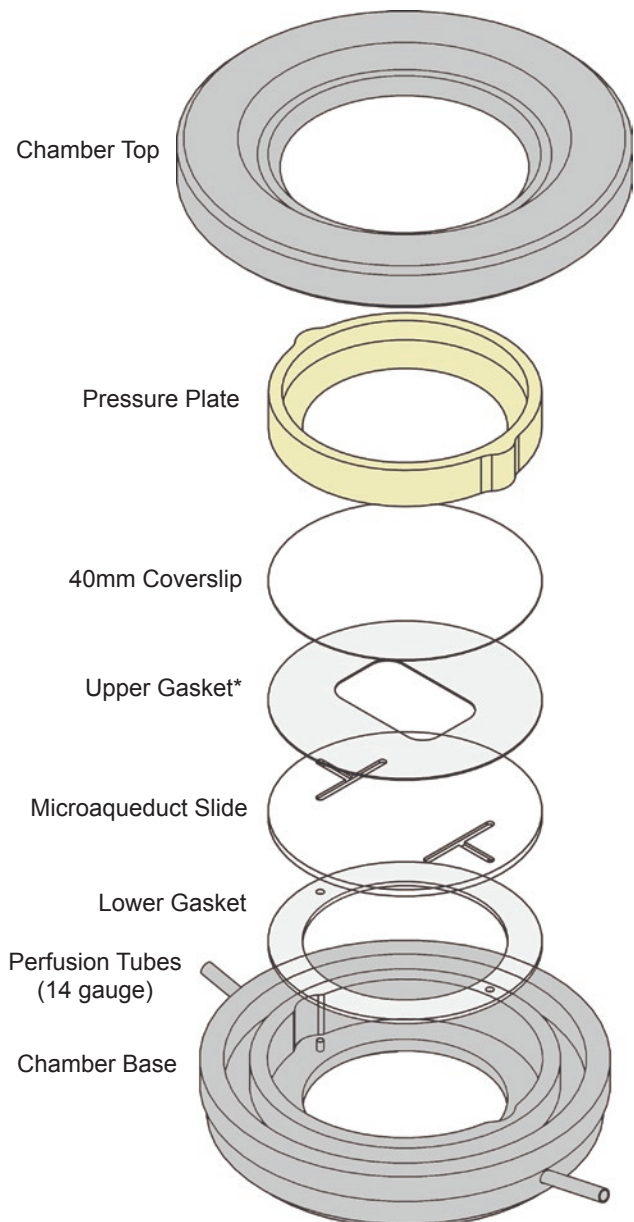

Typical FCS3® Perfusion Configuration for Induced Change Experiments

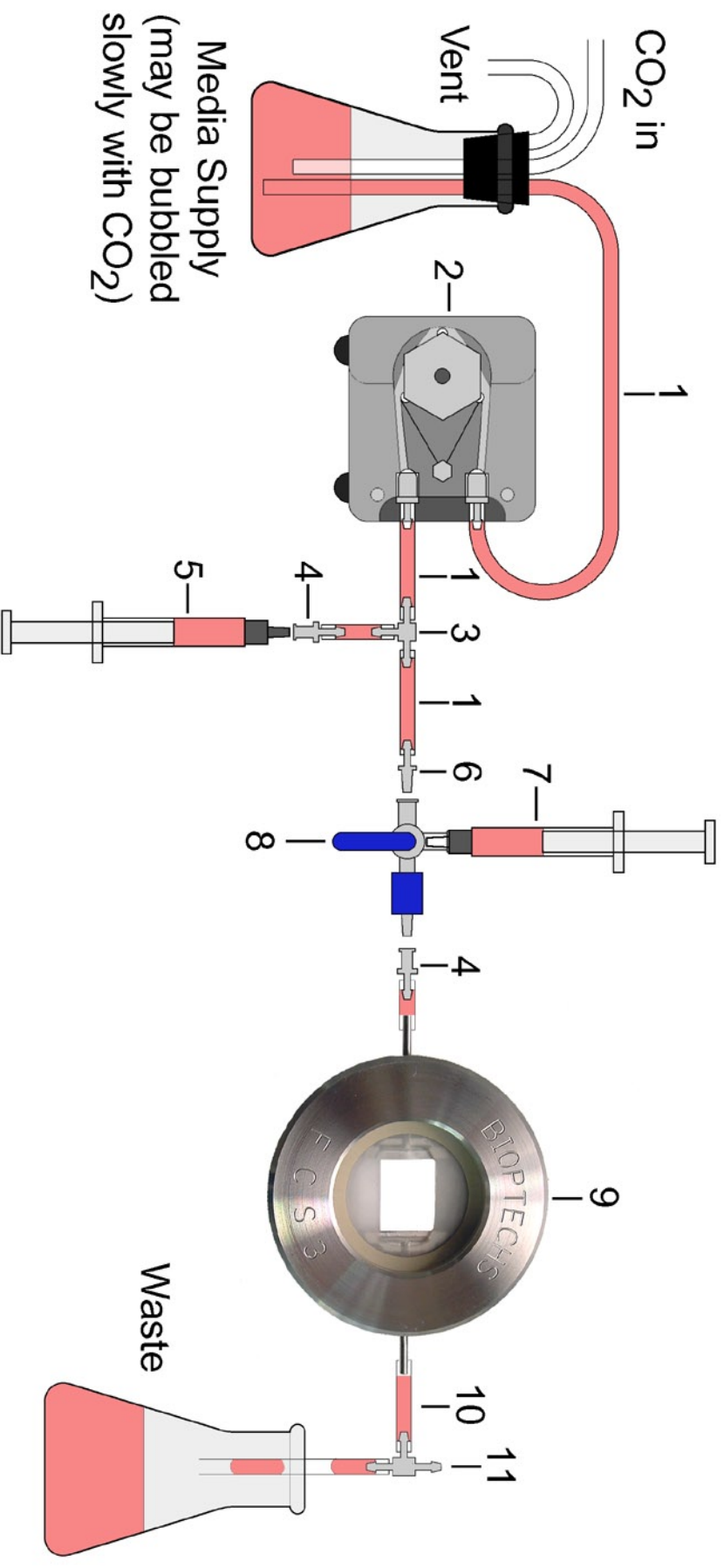

- 1 Perfusion tubing, 1/16" ID supply line (Keep as short as possible)
 - 2 FCS3 Micro-Perfusion Pump (recommended for prolonged, controlled perfusion in delicate optical cavities)
 - 3 Tee adapter (adds low volume syringe to facilitate manual perfusion when loading chamber)
 - 4 Luer adapter (female, adapts Luer taper syringe to 1/16" tubing)
 - 5 Low volume glass syringe
 - 6 Luer adapter (male, adapts 1/16" tubing to female Luer lock)
 - 7 Alternate media glass syringe (growth factors, inhibitors, etc.)
 - 8 Three-way valve (switches source of perfusion; pump or manual)
 - 9 FCS3 Chamber
 - 10 Tubing to waste container
 - 11 Tee adapter (place at same height as chamber, open top of tee to prevent siphoning)
- Note: Syringes are glass to prevent contamination of media from silicone lubricant typical in plastic syringes.

Biotech's Objective Temperature Control

The Problem:

When high numeric aperture objectives are used to observe temperature sensitive specimens, heat from the specimen is transferred through the optical coupling medium (oil, glycerine, or water) to the colder objective. Therefore, it is necessary to control the temperature of the objective. It is important to understand that when the system is set up properly, the objective heater is only used to prevent heat loss from the specimen. It should not be used to provide heat to the specimen.

The Wrong Solution:

Never use an objective heating device that does not transfer heat to the objective efficiently. Any heat that does not go into the objective will escape, convect upward and "overheat" your specimen!

The Right Solution:

To eliminate the heat loss from the specimen, Biotech's developed a patented Objective Heater System®, which includes a heater/sensor and an electronic controller specifically designed for this purpose. The heater/sensor is comprised of an adjustable thin-film heating band which surrounds 3/4 of the diameter of the upper region of the central retracting tube of the objective. A temperature probe positioned in the gap formed between the ends of the heating band provides accurate feedback to a closed loop controller. A metal cube shaped frame supports a thermal sensor and contains a mechanism to adjust the size of the heater-band.

The Objective Controller® is specifically designed to slowly heat the objective over a fifteen minute warm-up period, then hold the objective at the setpoint value within 0.1°C. The Controller operates from ambient to 50°C and has special safety circuitry which utilizes a 0.9°C error window to shut down the Controller and sound an alarm if the temperature of the objective deviates after it has reached setpoint.

The heater loop requires a minimum of 5mm longitudinal physical contact with a cylindrical surface on the objective. In some cases there may be a decorative collar on the objective that must be removed in order to permit adequate surface contact and efficient transfer of heat.

Special note:

1. When using warmed objectives it is recommended to use Type 37 Immerion Oil, available from Biotech's. This oil is specially formulated to have a refractive index of 1.518 at 37°C.
2. The Biotech's Objective Heater® can be adapted to fit all objectives. Due to the size, geometry and thermal characteristics of some objectives, it may be necessary to use a thermal spacer to eliminate the influence of the nosepiece.

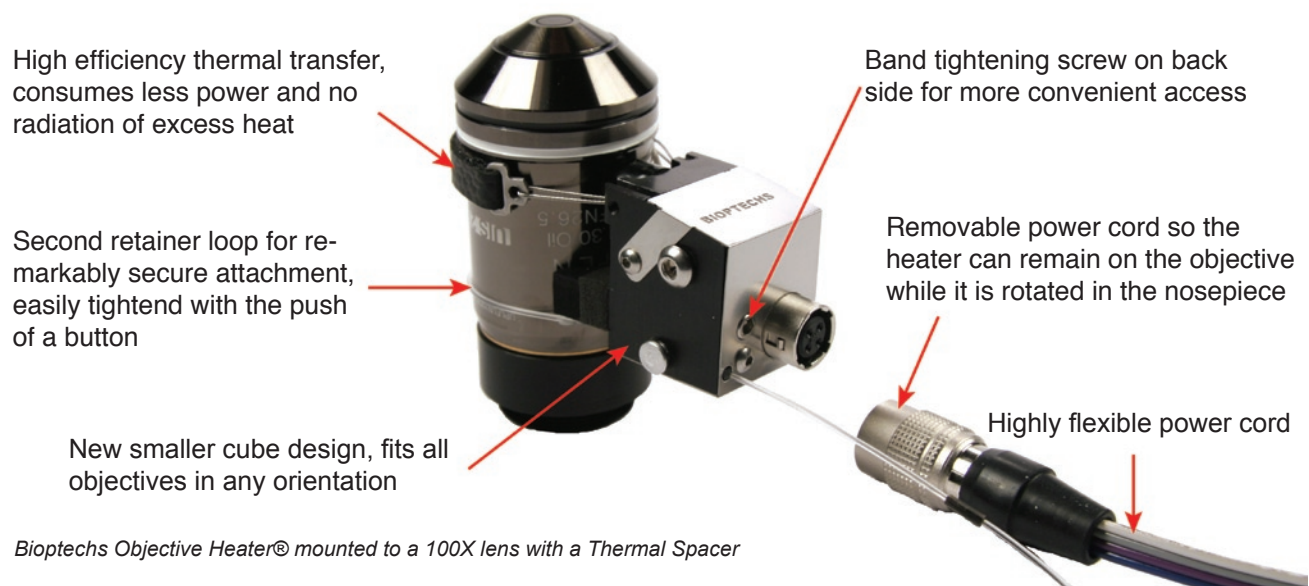

Objective Accessories

Biotechs Objective Cooling Collar

The Biotechs Cooling Collar is an attachment device designed to remove heat from an objective through fluid transfer. The Cooling Collar provides an isolated fluid passageway for chilled fluid to circulate around the objective thus absorbing heat by conduction to the adjacent metal surface. A separate chiller bath and circulating pump is required.

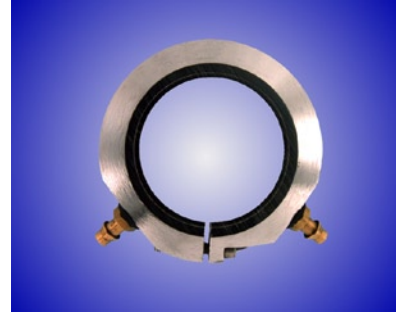

Biotechs PN 150303

Objective Thermal Isolator and Spacers

The Biotechs' Thermal Isolator is made of a material having low thermal conductivity for mounting objectives to the nosepiece of a microscope, which provides a gas trap to enclose the exposed optical elements from condensation. It is necessary to provide a supply of dry air or gas into the base of the Thermal Isolator. The Thermal Isolator will add 9mm to the height of the objective. Therefore, it is usually necessary to elevate the stage by the same amount. Due to the wide variety of stages available, Biotechs does not provide spacers for stage mounts. When the height of a microscope stage is adjusted by 9mm to accommodate the addition of a Thermal Spacer to one of the objectives, it is often convenient to adjust the height of the other objectives on the turret by the same amount. The Objective Spacer functions to add 9mm of height to an objective. **Note:** When ordering Objective Thermal Isolators or Spacers you must specify the thread type.



Thermal Isolators

Thermal Spacers

- RMS = 0.8" x 36 tpi (approximately 20mm diameter)
- 25mm x 0.75 mm/thread (approximately 1" diameter)

For RMS Thread:

Biotechs PN 152009R - Isolator

Biotechs PN 152019R - Spacer

For 25mm x 0.75mm Thread:

Biotechs PN 152009 - Isolator

Biotechs PN 152019 - Spacer

Biotechs Objective Wrench & Pliers

In order to expose sufficient surface for mounting heat transfer devices on some manufacturers' objectives, it is necessary to remove the outer decorative collar which contains written information such as magnification, N. A., etc. The objective wrench is designed to enable the user to isolate stress applied to an objective when removing this collar. The rotational force applied to the objective must be applied exclusively to the mounting threads and the cover. The wrench, designed with two thread sizes (0.8" X 36 TPI (RMS) and 25mm X 0.75mm/thread), securely binds these threads and provides sufficient leverage for removal of the cover.

Objective Wrench & Pliers

Objective with decorative collar removed



Biotechs PN 021523

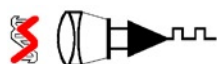

Micro-Perfusion Pump

When imaging cells on a coverslip in a chamber where liquid is confined, any changes in flow rate can translate to changes in pressure. This causes the coverslip to exhibit diaphragm-like behavior. Given the narrow depth of field of microscope objectives, this coverslip flexing causes the cells to go out of focus. To eliminate this problem at the lower flow rates and significantly reduce it at higher flow rates, Biopetechs recommends the Micro-Perfusion Pump for use with all its micro-observation systems.

The Micro-Perfusion Pump is a miniature, single or dual, channel full-featured peristaltic pump designed specifically for low-flow rates. Unlike most peristaltic pumps that are driven by stepper motors, the Micro-Perfusion Pump is driven by a tachometer regulated, multi-stage DC gear motor. This assures a smooth analog rotation of the roller spindle, free of instantaneous steps. It is regulated by either the internal control circuitry adjustable from 2-180 ml/hr or it can be interfaced with a computer through a DIO port. The pump comes with an external 9 Volt AC adapter, and also contains an internal 9 Volt battery which can function as the primary power supply if needed.

The pump includes a single 0.062" I.D. tube set for use as a single channel pump or a dual tube set that has two 0.062" I.D. tubes for use as a dual channel-pump. Although other tubing sizes are available, these two sizes are best suited for imaging applications. The pump tubes are made of C-Flex and are terminated with a 1/16" tubing barb. The base of the pump is threaded for easy mounting to a stand or fixture near the microscope.

Features

- Compact
- Usable as either single or dual channel
- Precise speed setting feature
- Flow rates of 2 to 180 ml/hr
- Compatible with 1/16" tubing
- External DC power supply with internal 9 volt backup battery
- Can be operated on internal battery if desired
- Preassembled autoclavable pump tubes
- Computer interfaceable

Back, Internal or External Speed Control,
Accepts External Power Supply.

Front, Accommodates One or Two Tubes



Biopetechs PN 060319131616 (FCS2)
Biopetechs PN 0420131616 (Delta T)



Options for the Micro-Perfusion Pump

Rod Mounting Clamp for Micro-Perfusion Pump

The Micro-Perfusions Pump Rod Mounting Clamp provides a method of mounting perfusion pumps onto a conventional one-half inch support post. This makes positioning perfusion pumps adjacent to the microscope easy and convenient.



Bioptechs PN 16181303

Single Channel Tubing Assembly for Micro-Perfusion Pump

The Single Channel Tubing Assembly for the Micro-Perfusion Pump is a precise length of either C-Flex or Silicon tubing, 0.0625" ID, bonded to termination blocks that anchor to the pump and provide 1/16th inch barb ends to attach additional tubing. The Single Channel tubing is typically used for FCS2 perfusion.

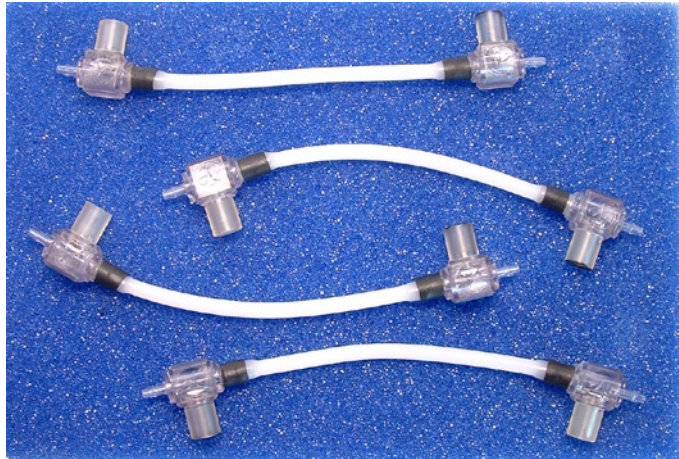

Bioptechs PN 060319192016 for C-Flex
Bioptechs PN 060319192016S for Silicon

Dual Channel Tubing Assembly for Micro-Perfusion Pump

The Dual Channel Tubing Assembly for the Micro-Perfusion Pump is made of two precise lengths of either C-Flex or Silicon Tubing bonded to termination blocks that anchor to the pump and provide 1/16th inch barb ends to attach additional tubing. The dual channel tubing is typically used for perfusion of the Delta T and its accessories. **Note:** The tube with the black band attached has a slightly smaller ID. Therefore the fluid flow is reduced through that tube as compared to the unmarked tube. When properly assembled (see *illustration on page 19*) this slight disparity in flow rates enables worry-free control of the fluid level in the dish.



Bioptechs PN 0420042016 for C-Flex
Bioptechs PN 0420042016S for Silicon



Perfusion and Temperature Control For Live-Cell Imaging!

The live-cell microscopy Perfusion and Temperature Control Interface from Bioptechs™ provides the following valuable features:

Extreme ease of use (fill in the blanks) for precise and repeatable control of:

- Dual or single micro-perfusion pumps
- Flow profile to reduce dead volume delays
- Temperature and perfusion recording
- Data logging of perfusion and temperature
- Multi-flow rate calibration
- Temperature profiling and cycling
- Saving and reloading settings
- Graphic display of events

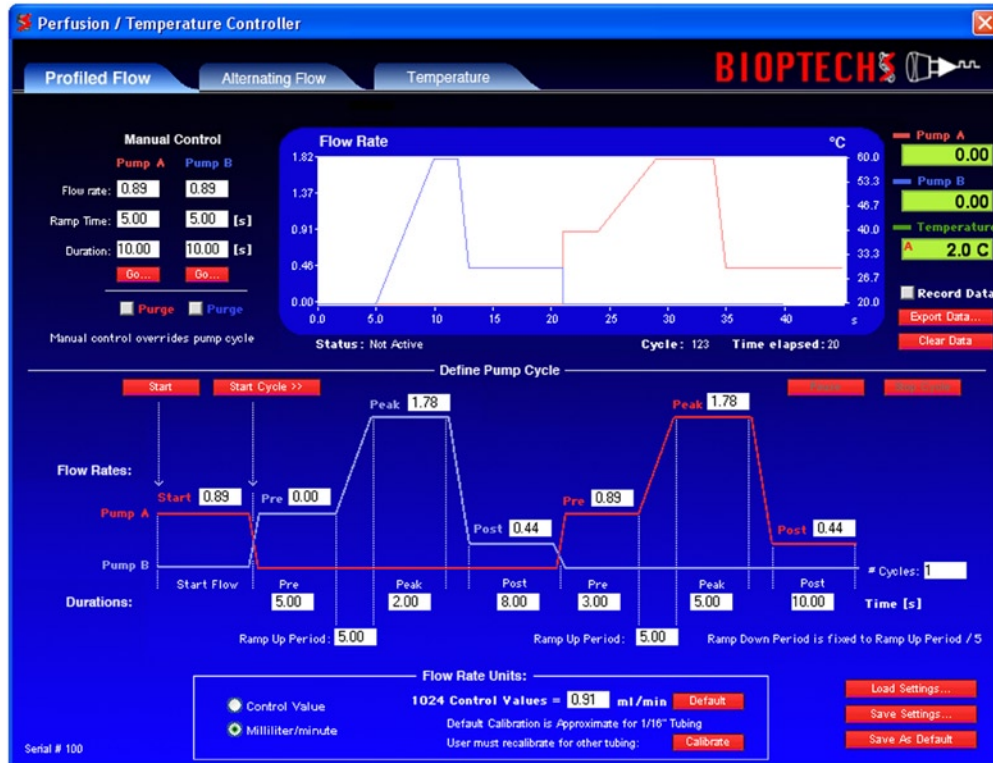

Graphic represents one of three different control screens:

- Profiled Flow (allows control of acceleration rates during pump speed changes)
- Alternating Flow (immediate transition from one pump to another)
- Temperature (programming and recording)

Bioptechs PN 13161603-13 (USB)

This intuitive control interface system is optimized for time-lapse imaging of live-cell activity. It provides a convenient, accurate, reliable, and repeatable method of controlling fluid and temperature for chemically or thermally induced change experiments in live-cell chambers. WYSIWYG on both Mac and PC platforms!

System includes: Program CD, USB Dongle, External USB interface and cabling, Instructions Manual, and Self Help Wall Poster. Note: Temperature programming and recording of Bioptechs products only. Temperature recording with USB interface only.

System Requirements: USB Mac or USB PC - Windows 2000 or XP, and two Bioptechs Micro-Perfusion pumps (for controlled perfusion) or a Bioptechs Temperature Controller FCS2, FCS3, Delta T, or Objective Heater (for temperature control).



Perfusion Tubing

It is important to use a tubing suitable for cell culture and compatible with the environmental apparatus. The main considerations for tubing are:

- Size
- Biocompatibility
- Gas permeability
- Autoclavability
- Transparency

Typically, 1/16th" inside diameter tubing is more than adequate to perfuse the small volumes of cells that are used on a microscope. The 1/16th" diameter provides adequate flow and is easily workable. There are several choices that Biopetechs has found to be suitable for microscopy applications. All have excellent biocompatibility and nearly zero gas permeability. The main differences are the survivability of autoclaving and transparency. Transparency is an issue when a parallel plate chamber is used. If any bubbles form during the perfusion process and get into the parallel plate optical cavity, they will adhere to the glass and potentially ruin an experiment. If a transparent tubing is used, the bubbles can be seen, giving you time to trap and eliminate them before they do harm. The final issue is autoclaving. All three of the top biocompatible tubings claim autoclavability. However, some survive better than others. The following chart represents Biopetechs' experience in testing these materials.

Material	Size	Gas Permeability	Transparency	Autoclavability
C-Flex	1/16"		Translucent	Excellent
Pharmed	1/16"		Opaque	Unknown
Tygon 2275	1/16"		Nearly transparent	Fair

Biopetechs PN 20202275 for Tygon (25ft)
Biopetechs PN 2020822 for C-Flex (50ft)

Biopetechs recommends and sells C-Flex tubing. It is available in the 1/16" ID size and sold in 50 foot reels.

- **C-Flex is a unique patented thermoplastic elastomer specifically formulated to meet the critical demands of medical, and pharmaceutical, research.**
- **C-Flex contains no toxic extractables (non-PVC, non-latex, non-silicone)**
- **Complies with USP XXII, Class VI, FDA and USDA standards.**
- **Manufactured under strict GMP's in an FDA registered facility**
- **Significantly less permeable than silicone**
- **Low protein binding**
- **Ultra smooth inner bore**
- **Safely disposable**



Reference Information

Biotechs' Temperature Control System Algorithm

The five input values read by the controller are:

1. User set point
2. Dish temperature below 0.9°C below user setpoint
3. Dish temperature from 0.9°C below user setpoint to 0.1°C below setpoint
4. Dish temperature between user setpoint minus 0.1°C and user setpoint (control resolution)
5. Dish temperature at or above set point

There are six conditions that affect the output:

[a] Object temperature is below 0.9°C below user setpoint (cold startup mode). The heater output starts at 0 volts and increases at a fixed rate to a maximum value.

[b] Object temperature increases above 0.9°C below user setpoint and below setpoint -0.1°C. A latch is set for condition [f] and output voltage acceleration rate decreases from cold startup mode and the output voltage is set at a rate about five times the minimum decay rate.

[c] Object temperature is above user setpoint. The output voltage is reduced to one-third its previous value and decays at an accelerated rate until condition [d] or [e] occurs.

[d] Object temperature falls from above user setpoint to within control resolution band. The output voltage is held steady at the previous high state value, minus the accelerated decay value if present, at a minimum decay rate. (Accelerated decay value present only if preceded by condition [c].)

[e] Object temperature is within control resolution band. The output voltage is held steady but decays at a minimum rate.

[f] Object temperature or thermistor reading falls below 0.9°C below user setpoint. The output voltage is shut off to the object and an alarm sounds until the user cancels the alert by pressing the red button. This occurs if the temperature sensor is subject to cold shock. The amplitude, gain and decay rate, maximum current, operating current, response time, sensitivity, alarm range, and bandwidth are all variables that are adjusted specifically for each type of controller. Although each type of controller auto-ranges, its range of accommodation is limited to the typical thermal load of the object it is regulating. Each channel is controlled separately but both share the same setpoint.

Industry Standard Thickness for Coverslip Glass:

#00 = 0.060 - 0.080	#2 = 0.170 - 0.250
#0 = 0.080 - 0.120	#3 = 0.280 - 0.320
#1 = 0.130 - 0.170	#4 = 0.380 - 0.420
#1.5 = 0.160 - 0.190	#5 = 0.500 - 0.600

Microscope Stage Types:

Single plate stage is defined by a thick metal plate that uses a separate mechanical specimen translator to slide the specimen on the surface of the stage. Friction occurs between the specimen and surface of the stage. The specimen sometimes is placed into an adapter plate.

Triple plate stage is made of three individual plates; bearing mounted, to eliminate friction between the plates. The specimen is placed in or on the top plate and both the specimen and the top plate move together. This is a premium stage with the best X, Y, Z stability.

Motorized Stages are usually of the triple plate type and provide automation and superior repeatability.



Micro-Environmental System Profile Questions

This list of questions is fundamental to identifying the appropriate components of a micro-environmental system. Completion of this list prior to contacting Biotech will optimize the exchange of technical information. Please copy and fax this report to Biotech prior to contacting us by phone. Fax 724-282-0745

Name: _____ Institution: _____ Phone: _____

Fax: _____ Email: _____

1. Who is the brand & model of microscope? Carl Zeiss Leica Nikon Olympus Model: _____

2. What type of microscope? Upright Inverted

3. What is the brand of the stage? Carl Zeiss, Leica, Nikon, Olympus, Marzhauser, Ludl, Prior, ASI, etc.

4. What type of stage for inverted microscopes? Single plate Triple plate

5. What mode or combinations of modes of microscopy will be used?

Brightfield	Darkfield	Phase
DIC	Polarization	Modulation Contrast
Reflection Interference	Fluorescence	Multi-Photon
Standing Wave	VAREL	Confocal

6. Which types of objectives and their magnifications? (include all that apply)

Inverted microscopes: 4X, 5X, 10X, 20X, 40X dry, (40 X, 63X, and 100X fluid coupled)

Upright microscopes: 4X, 5X, 10X, 20X, (other magnifications require water dipping lenses for Delta T use)

7. What is the condenser N.A.? (relates to working distance) Common values: 0.3-0.6, 0.7-0.9, 1.0 - 1.4

8. What is the imaging scenario? Single image Time lapse (interval) _____

9. What is the duration of time specimens will be on the microscope? (minutes, hours, days) _____

10. How will the correlation of optical contrast images to other modes such as fluorescence be recorded?

No contrast images First image only Contrast image with every fluorescence image

11. What type of experiment or object of experiment? (brief explanation)

12. What is the specimen type?

Adherent monolayer Cell suspension Natural tissue Artificial membrane

13. What temperature do the specimens need to be maintained? _____ °C

14. What is the appropriate chamber type? Open Closed

15. Will micromanipulators be used and when? Before imaging During imaging Both

16. Does the specimen need perfusion of media and what is the perfusion profile?

Intermittent (manual) Automated Continuous Single or multiple perfusate sources

Explain:

17. Will CO₂ dependent media be used or other gas regulation be necessary? CO₂ _____, Gas reg. _____



Check List for Ordering an FCS2® or FCS3®

Having established the need for a closed system, there are a few technical matters that should be considered. Following this guide will ensure that these areas have been addressed.

The FCS2 and FCS3 are used for both high and low numeric aperture applications. Therefore, the objective heater and objective temperature controller are sold separately. The main optional consideration is perfusion.

When Ordering an FCS2 or FCS3 System:

1. Select a stage adapter from the FCS2 stage adapter page and provide the microscope manufacturer's name and model of stage to confirm identification of the appropriate adapter. (See pg 28) If ordering FCS3 skip to #2.
2. If the cells need perfusion, the following items should be included on the order:
 - Micro-Perfusion Pump Bioptechs PN 060319131616
 - C-Flex tubing (50ft) Bioptechs PN 2020822

or

 - Tygon tubing (25ft) Bioptechs PN 20202275
 - Bioptechs Perfusion Connector Kit, Bioptechs PN 162003-1
Includes: Male Luer adapter
Two Female Luer adapters,
"T" adapter & Three-way Luer valve
3. Although the starter set comes with 50 coverslips, you may want to order additional coverslips.
Bioptechs PN 40-1313-0319 (250pk)
4. If high numeric aperture objectives are to be used, you will need to order the following:
Objective Heater Controller Bioptechs PN 150803

---AND---

An Objective Heater* (three sizes available)

14 - 22mm diameter	Bioptechs PN 150819-1913
19 - 27mm diameter	Bioptechs PN 150819
23 - 33mm diameter	Bioptechs PN 150815
30 - 37mm diameter	Bioptechs PN 150812

* We cannot guarantee that our stock Objective Heater fits all objectives. Therefore we ask that you specify the make, magnification, N.A. and any other attributes of the objectives you intend to use. This step will assist us in determining the compatibility of our Objective Heater with your optics

5. Indicate the N.A. of the transmitted condenser if it will be used.
6. Supplemental components for FCS2 operation at temperatures below ambient are:
 - FCS2 Cooling Adapter (fits all FCS2's) Bioptechs PN 060319 0301
 - Objective Cooling Collar Bioptechs PN 150303
(individually machined to fit users own objective)
 - Objective Thermal-Isolator *For RMS Thread:*
(Available for infinity corrected objectives Bioptechs PN 152009R - Isolator
with an anti-reflective coated window, Bioptechs PN 152019R - Spacer
160mm tube-length objectives require a *For 25mm x 0.75mm Thread:*
compensating lens at an additional charge) Bioptechs PN 152009 - Isolator
Bioptechs PN 152019 - Spacer



Check List for Ordering a Delta T[®] Culture Dish System

Having established the need for an open dish system, there are a few technical matters that should be considered. Following this guide will ensure that these areas have been addressed.

When Ordering a Delta T System:

1. Provide the microscope manufacturer's name and model of your stage to identify the appropriate adapter.
2. Indicate the type of specimen.
 - a. In the case of adherent cultured cells and low N.A. objectives, you will only need the basic Delta T system. It is comprised of a Delta Stage Adapter and a Delta T Dish Controller plus a suitable quantity of 0.5mm dishes.
 - b. If the specimen is a natural membrane, cut section, or tissue slice, an appropriate specimen carrier will need to be added to the basic system. (*see Tissue Slice, Brain Slice, and Artificial Membrane pages*).
3. Determine if high or low N.A. lenses will be used. Order the appropriate dishes for the N.A. of the objectives.
 - For low N.A. applications, order 0.5mm thick bottomed dishes, Bioprotechs PN 04200405
 - For high N.A. applications, order #1.5 coverslip bottomed dishes, Bioprotechs PN 04200415Note: If the application involves Fluorescence, add the suffix B to specify black sidewall dishes. Clear dishes are shipped with clear lids & black dishes are shipped with black lids.

4. If the cells need perfusion, the following items should be included on the order:

If media surface can be open to atmospheric air use:

Delta T Hinged Perfusion Adapters	Bioprotechs PN 0420081601
Delta T Micro-Perfusion Pump	Bioprotechs PN 0420131616
C-Flex tubing (50ft)	Bioprotechs PN 2020822

or

Tygon tubing (25ft)	Bioprotechs PN 20202275
---------------------	-------------------------

If media must be closed to atmospheric exposure:

Delta T Perfusable Coverglass Lid :	Bioprotechs PN 0420031216
-------------------------------------	---------------------------

5. If contrast enhancement techniques are used for transmitted images on an inverted microscope, consider the option of a Heated Lid:

Perfusable Heated Lid	Bioprotechs PN 04200803
	Bioprotechs PN 0420080316

6. If a series of optically induced contrast images are to be made into a movie loop, the Coverglass Lid, with or without perfusion, is advisable.

Delta T Coverglass Lid	Bioprotechs PN 04200312
Delta T Perfusable Coverglass Lid	Bioprotechs PN 0420031216

7. If high numeric aperture objectives are to be used at physiological temperatures, you will need to order the following:

Objective Heater Controller	Bioprotechs PN 150803
-----------------------------	-----------------------

----AND----

An Objective Heater* (four sizes available)

14 - 22mm diameter	Bioprotechs PN 150819-1913
19 - 27mm diameter	Bioprotechs PN 150819
23 - 33mm diameter	Bioprotechs PN 150815
30 - 37mm diameter	Bioprotechs PN 150812

* We cannot guarantee that our stock Objective Heater fits all objectives. Therefore, we ask that you specify the make, magnification, N.A. and any other attributes of the objectives you intend to use. This step will assist us in determining the compatibility of our Objective Heater with your optics.

If the temperature of the specimen needs to be below ambient, include the Delta T Cooling Ring attachment.
Bioprotechs PN 04200318



How to Size Your Objective

A is the diameter of the spring loaded retractable portion of the objective. This is the diameter that the heater band must fit.

B is the minimum vertical surface needed to mount the Objective Heater and transfer heat.

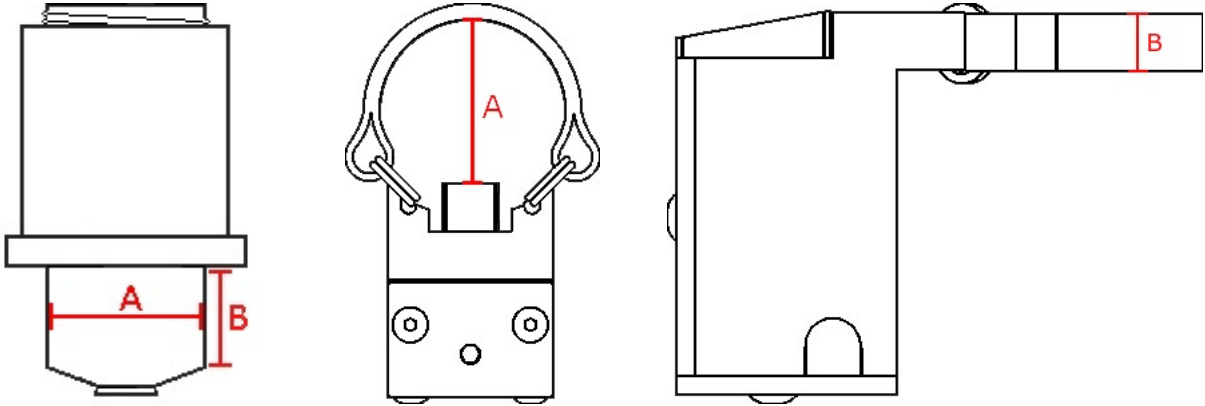

Biotechs Objective Heater Band Sizes:

Small	Standard	Medium	Large
A - 14 - 22 mm	A: 19 - 27 mm	A: 23 - 33 mm	A: 30 - 37 mm
B - 5.5 mm	B: 5.5 mm	B: 6mm	B: 3.5 mm
Biotechs PN 150819-1913	Biotechs PN 150819	Biotechs PN 150815	Biotechs PN 150812

Please note that the above diagram depicts a typical Objective Heater mounting location. There are a wide variety of objective configurations. Therefore it may be necessary to mount an Objective Heater at a different location than indicated above. If the geometry of your objective will not accommodate an Objective Heater, contact us via email (info@biotechs.com) or fax us with the information below. Please add your contact information and we will give you a definite answer as to whether your objective can accept an Objective Heater. Please send faxes, Attn: Sales, Fax: (724)282-0745.

Your measurement for Dimension **A** _____ mm or _____ inches.

Your measurement for Dimension **B** _____ mm or _____ inches.

Your Objective Manufacturer: _____

Your Objective Specifications: _____

Some objectives require the removal of a decorative collar as shown below. If removal of a decorative collar is required an objective wrench and pliers are available from Biotechs.



Objective

Inside of Objective

Outer Shield of Objective

Objective with Heater Installed



Objective Wrench and Pliers
Biotechs PN 021523



Bioptechs Delta T® Price Schedule

Product	Part Number	Domestic	Export
Delta T Starter Set <i>Includes the following:</i>	0420-4	\$3,350.00	\$3,852.50
<i>Delta T Controller, Heated Lid, Coverglass Lid, Culture Cylinder Pack: (1) 4mm, (1) 6mm, (1) 8mm, (1) 10mm, 0.17mm clear dishes (10/pk), Standard Stage Adapter (please specify which stage when ordering)</i>			
Delta T Culture Dish System (Page 14)			
Delta T Culture Dish Controller	0420-4-03	\$2,500.00	\$2,875.00
Delta T Culture Dish Stage Adapters (Page 25)			
96-Well Plate Sized Adapter	04202003	\$550.00	\$632.50
Leica DMIRB Triple Plate Adapter	04201203	\$550.00	\$632.50
Nikon, Olympus, Deltavision Adapter	04201415	\$550.00	\$632.50
Upright Universal Adapter	04202116	\$550.00	\$632.50
Marzhauser, Zeiss (K), ASI, Ludl & Prior Adapter	04202602	\$550.00	\$632.50
Zeiss (G) Adapter	04202603	\$550.00	\$632.50
Zeiss (M) & Leica Single Plate Adapter	04202601	\$550.00	\$632.50
Custom Delta T Stage Adapters:			
Cell Robotics Adapter	04201220	\$750.00	\$862.50
Leica Galvanic Adapter (Round)	04201207	\$750.00	\$862.50
Leica Galvanic Adapter (Rectangular)	04201807	\$750.00	\$862.50
Marzhauser Galvanic Adapter (Rectangular)	04202807	\$750.00	\$862.50
Delta T Culture Dishes (10/pk) (Page 15)			
0.5mm thick glass (clear)	04200405	\$57.50	\$66.13
0.17mm thick glass (clear)	04200415C	\$57.50	\$66.13
0.17mm thick glass (black)	04200415B	\$57.50	\$66.13
Delta TPG Uncoated (no temperature control) Culture Dishes (10/pk)			
0.5mm thick glass	0420040500	\$35.00	\$40.25
0.17mm thick glass	0420041500C	\$35.00	\$40.25
0.17mm thick glass	0420041500B	\$35.00	\$40.25
Delta T Culture Dish Accessories (Page 17)			
Tissue Slice Adapter	0420201918	\$350.00	\$402.50
Artificial Membrane Adapter	0420011301	\$400.00	\$460.00
Brain Slice Adapter	0420201919	\$400.00	\$460.00
Hinged Perfusion Adapter Set (2/set)	0420081601	\$300.00	\$345.00
Cooling Ring	04200318	\$150.00	\$172.50
Heated Lid	04200803	\$300.00	\$345.00
Perfusable Heated Lid	0420080316	\$375.00	\$431.25
Atmospheric Barrier Ring	04200325	\$50.00	\$57.50
Coverglass Lid	04200312	\$150.00	\$172.50
Perfusable Coverglass Lid	0420031216	\$250.00	\$287.50
Media Volume Reducer	04200303	\$300.00	\$345.00
Yeast Slide Adapter	042005076	\$500.00	\$575.00
Perfusion (Page 35)			
Delta T Micro-Perfusion Pump	0420131616	\$995.00	\$1,144.25
Delta T Dual Channel Tubing Assembly (4/set) C-Flex	0420042016	\$125.00	\$143.75
Delta T Dual Channel Tubing Assembly (4/set) Silicon	0420042016S	\$125.00	\$143.75
1/16" Tygon 2275 Tubing (25 ft)	20202275	\$55.00	\$63.25
C-Flex Tubing (50 ft)	2020822	\$90.00	\$103.50
Perfusion Pump Rod Mounting Clamp	16181303	\$25.00	\$28.75
Perfusion/ Temperature Controller (USB interface)	13161603-13	\$3,200.00	\$3,680.00
Objective Heater System			
See Catalog Page 39			
Glass Culture Cylinders			
See Catalog Page 26			
Note: 1. Bioptechs reserves the right to change prices.			
2. The prices listed above are stated in US \$.			



Bioprotechs FCS2® & FCS3® Price Schedule

Product	Part Number	Domestic	Export
FCS2 System (Page 28)			
FCS2 Starter Set (includes:)	060319-2	\$4,000.00	\$4,600.00
<i>FCS2 Chamber, Chamber Controller, 5 Microaqueduct Slides, 50-40mm Coverslips, and Gasket Set (30/set)</i>			
FCS2 Stage Adapters (Page 34)			
Cell Robotics Adapter	060319-2-0318	\$330.00	\$379.50
Leica DMIRB Triple Plate Adapter	060319-2-12	\$550.00	\$632.50
Nikon, Olympus, Deltavision Adapter	060319-2-1415	\$375.00	\$431.25
Zeiss (K), ASI, Ludl & Prior Adapter	060319-2-2611	\$650.00	\$747.50
Zeiss (M) & Leica Single Plate Adapter	060319-2-2613	\$500.00	\$575.00
Closed Chamber Supplies			
FCS2 Chamber	060319-2-03	\$1,650.00	\$1,897.50
FCS2 Chamber Controller	060319-2-0303	\$2,000.00	\$2,300.00
Microaqueduct Slides (5/pk)	130119-5	\$350.00	\$402.50
40mm Coverslips (250/pk)	40-1313-0319	\$200.00	\$230.00
40mm Coverslips (500/pk)	40-1313-03192	\$350.00	\$402.50
40mm Coverslips (1000/pk)	40-1313-03193	\$650.00	\$747.50
FCS2 Gasket Set (30/set)	060319-2-0719	\$150.00	\$172.50
FCS2 Accessories (Page 32)			
FCS2 Cooling Adapter	060319-2-0301	\$400.00	\$460.00
FCS2 Open Mode Adapter	060319-2-1513	\$175.00	\$201.25
FCS2 Low Dead Volume Top	060319-2-1242	\$495.00	\$569.25
Cooled FCS2 (CFCS2)	03060319-2	\$2,500.00	\$2,875.00
Perfusion (Page 30)			
FCS Micro-Perfusion Pump	060319131616	\$995.00	\$1,144.25
FCS Single Channel Tubing Assembly (4/pk) C-Flex	060319192016	\$125.00	\$143.75
FCS Single Channel Tubing Assembly (4/pk) Silicon	060319192016S	\$125.00	\$143.75
1/16" Tygon 2275 Tubing (25 Ft)	20202275	\$55.00	\$63.25
1/16" C-Flex Tubing (50 Ft)	2020822	\$90.00	\$103.50
1/16" Perfusion Adapter Set	162003-1	\$15.00	\$17.25
Micro-Perfusion Pump Rod Mounting Clamp	16181303	\$25.00	\$28.75
Perfusion/Temp Control (USB Interface)	13161603-13	\$3,200.00	\$3,680.00
FCS3 System (Page 35)			
FCS3 Starter Set (includes:)	21-060319-3	\$4,000.00	\$4,600.00
<i>FCS3 Chamber, Chamber Controller, 5 Microaqueduct Slides, 50- #1.5, 40mm Coverslips, and Gasket Set (30/set)</i>			
Note: FCS2 and FCS3 gaskets, coverslips, and microaqueduct slides are interchangeable			
FCS3 Universal Upright Stage Adapter	21-060319-3-08	\$1,000.00	\$1,150.00
FCS3 Zeiss A Stage Adapter	21-060319-3-2601	\$1,000.00	\$1,150.00
FCS3 K Stage Adapter	21-060319-3-2611	\$1,250.00	\$1,437.50
FCS3 Chamber	21-060319-3-03	\$2,602.00	\$2,992.30
FCS3 Chamber Controller	21-060319-3-0303	\$2,000.00	\$2,300.00
FCS3 Spanner Wrench	21-060319-3-1923	\$54.00	\$62.10
FCS3 Pressure Plate	21-060319-3-16	\$36.00	\$41.40
Thermal Slide System			
Thermal Slide Starter Set (Includes:)	2019-1919-0	\$1,700.00	\$1,955.00
<i>Thermal Slide Controller, Controller Stand, Controller Power Supply, Thermal Slide Carrier, (1pk) 5qty Thermal Slides</i>			
Thermal Slide Controller w/ Power Supply	2019-1919-3	\$1,285.00	\$1,477.75
Thermal Slide Carrier	2019-1919-1	\$375.00	\$431.25
Thermal Slide Pack (5 qty)	2019-1919-2	\$150.00	\$172.50

Note: 1. Bioprotechs reserves the right to change prices.

2. The prices listed above are stated in US \$.



Product	Part Number	Domestic	Export
Objective Heater System (Page 39)			
Objective Heater Controller	150803	\$1,500.00	\$1,725.00
Objective Heater Small	150819-1913	\$625.00	\$718.75
Objective Heater Standard	150819	\$625.00	\$718.75
Objective Heater Medium	150815	\$665.00	\$764.75
Objective Heater Large	150812	\$700.00	\$805.00
37 Degree Immersion Oil	150825	\$6.25	\$7.19
Objective Wrench & Pliers	021523	\$175.00	\$201.25
Objective Thermal Isolator RMS	152009R	\$500.00	\$575.00
Objective Thermal Isolator 25mm	152009	\$500.00	\$575.00
Objective Thermal Spacer RMS	152019R	\$100.00	\$115.00
Objective Thermal Spacer 25mm	152019	\$100.00	\$115.00
Objective Cooling Collar	150303	\$700.00	\$805.00
Boekel Warmer	260700	\$250.00	\$316.25
Stable "Z" System			
Stable Z Starter Set	403-1926	\$1,775.00	\$2,041.25
<i>Includes: Stable Z Controller, Stable Z Controller Holder, Stable Z Controller Power Supply, and Stable Z Stage Adapter (Please specify which stage adapter when ordering)</i>			
Stable Z Controller	403-1926-03	\$1,285.00	\$1,477.75
K Stage Adapter	403-1926-19-11-K	\$590.00	\$678.50
Nikon Stage Adapter	403-1926-19-14-N	\$590.00	\$678.50
Olympus Stage Adapter	403-1926-19-15-O	\$590.00	\$678.50
SBS Stage Adapter	403-1926-19-19-S	\$590.00	\$678.50
A Stage Adapter	403-1926-19-2601-A	\$590.00	\$678.50
Nunc Lab-Tek™ Warming Adapter	403-1323	\$825.00	\$948.75
Replacement Reference Thermistor	403-1926-1820	\$21.00	\$24.15
Interchangeable Coverslip Dish Set	190310	\$80.00	\$92.00
<i>Includes: Dish Base, 10mm Threaded Insert, (2) o-rings, (50pk) 30mm Coverslips</i>			
Interchangeable Coverslip Dish Set (10+)	190310	\$65.00 per	\$74.75 per
<i>Special Pricing When Ordering 10+ Includes: (10+) Dish Base, (10+) 10mm Threaded Insert, (20+) O-rings, (500+pk) 30mm coverslips</i>			
30mm Coverslips (#1.5) Qty 100	301313-0319	\$27.00	\$31.05
EDU Culture Dish Control System			
EDU Starter Set	0420-050421-2	\$1,175.00	\$1,351.25
<i>Includes: EDU Controller, EDU Controller Power Supply, EDU Stage Adapter, (1pk) 10qty clear dishes, (1pk) 100 qty 22mm coverslips, 22mm Glass Spacer, Coverslip Weight, 6mm Culture Cyl</i>			
EDU Controller w/ Power Supply	0420-050421	\$600.00	\$690.00
EDU Stage Adapter	0420-050421-1	\$400.00	\$460.00
Glass Culture Cylinders (Page 26)			
Starter Set (2, 4, 6, 8, 10 mm)	070303-1919	\$125.00	\$143.75
1 mm Inner Diameter x 5mm high	070303-01	\$25.00	\$28.75
2 mm Inner Diameter x 5mm high	070303-02	\$25.00	\$28.75
4 mm Inner Diameter x 5mm high	070303-04	\$25.00	\$28.75
6 mm Inner Diameter x 5mm high	070303-06	\$25.00	\$28.75
8 mm Inner Diameter x 5mm high	070303-08	\$25.00	\$28.75
10 mm Inner Diameter x 5mm high	070303-10	\$25.00	\$28.75
12 mm Inner Diameter x 5mm high	070303-12	\$25.00	\$28.75
14 mm Inner Diameter x 5mm high	070303-14	\$25.00	\$28.75



References

This is not a complete list of Bioprotech's references, a keyword searchable database of these and many other references are available on the Bioprotech web site. www.bioprotech.com

Title	Citation	Authors
The Zn ²⁺ transporting pathways in pancreatic beta-cells: A role for the L-type voltage-gated Ca ²⁺ channel	J. Biol. Chem. published 30 December 2005, 10.1074/jbc.M508542200	Armen V. Gyulkhandanyan, Simon C. Lee, George Bikopoulos, Feihan Dai, and Michael B. Wheeler
Distinct Morphological Stages of Dentate Granule Neuron Maturation in the Adult Mouse Hippocampus	J. Neurosci. 2006; 26(1): p. 3-11	Chunmei Zhao, E. Matthew Teng, Robert G. Summers, Jr, Guo-li Ming, and Fred H. Gage
A transport mechanism for NAADP in a rat basophilic cell line	FASEB J. published 10 January 2006, 10.1096/fj.05-5058fje	R. A. Billington, E. A. Bellomo, E. M. Floriddia, J. Erriquez, C. Distasi, and A. A. Genazzani
A role for the septation initiation network in septum assembly revealed by genetic analysis of sid2-250 suppressors	Genetics published 16 January 2006, 10.1534/genetics.105.050955	Quan-wen Jin, Mian Zhou, Andrea Bimbo, Mohan K Balasubramanian, and Dannel McCollum
Kinetics of penetration influence the apparent potency of vanilloids on TRPV1	Mol. Pharmacol. published 17 January 2006, 10.1124/mol.105.019158	Jozsef Lazar, Derek C. Braun, Attila Toth, Yun Wang, Larry V. Pearce, Vladimir A. Pavlyukovets, Peter M. Blumberg, Susan H. Garfield, Stephen Wincovitch, Hyun-Kyung Choi, and Jeewoo Lee
Regulation of N-Cadherin Dynamics at Neuronal Contacts by Ligand Binding and Cytoskeletal Coupling	Mol. Biol. Cell. 2006; 17(2): p. 862-875	Olivier Thoumine, Mireille Lambert, Rene-Marc Mege, and Daniel Choquet
Cell Cycle-dependent Recruitment of Telomerase RNA and Cajal Bodies to Human Telomeres	Mol. Biol. Cell. 2006; 17(2): p. 944-954	Beata E. Jady, Patricia Richard, Edouard Bertrand, and Tamas Kiss
Localized recruitment and activation of RhoA underlies dendritic spine morphology in a glutamate receptor-dependent manner	J. Cell Biol. 2006; 172(3): p. 453-467	Vanessa Schubert, Jorge Santos Da Silva, and Carlos G. Dotti
A functional module of yeast Mediator that governs the dynamic range of heat shock gene expression	Genetics published 1 February 2006, 10.1534/genetics.105.052738	Harpreet Singh, Alexander M Erkin, Selena B. Kremer, Harry M Duttweiler, Donnie A Davis, Javed Iqbal, Rachel R Gross, and David Gross
Disruption of SLP-76 Interaction with Gads Inhibits Dynamic Clustering of SLP-76 and Fc{varepsilon}RI Signaling in Mast Cells	Mol. Cell. Biol. 2006; 26(5): p. 1826-1838	Michael A. Silverman, Jonathan Shoag, Jennifer Wu, and Gary A. Koretzky
CLIP-170 Homologue and NUDE Play Overlapping Roles in NUDF Localization in Aspergillus nidulans	Mol. Biol. Cell published 8 February 2006, 10.1091/mbc.E05-11-1084	Vladimir P. Efimov, Jun Zhang, and Xin Xiang
The beta-agonist isoproterenol attenuates EGF-stimulated wound closure in human airway epithelial cells	AJP: Lung. 2006; 290(3): p. L485-L491	Bradley J. Schnackenberg, Stacie M. Jones, Crystal Pate, Brian Shank, Laura Sessions, Laura M. Pittman, Lawrence E. Cornett, and Richard C. Kurten
Myo1c binds tightly and specifically to phosphatidylinositol 4,5-bisphosphate and inositol 1,4,5-trisphosphate	Proc. Natl. Acad. Sci. USA published 21 February 2006, 10.1073/pnas.0505685103	David E. Hokanson and E. Michael Ostap
PKG phosphorylates Pak1, inhibiting Pak/Nck binding and stimulating Pak/VASP association	J. Biol. Chem. published 20 February 2006, 10.1074/jbc.M600279200	Benjamin H. Fryer, Changhui Wang, Srilakshmi Vedantam, Guo-Lei Zhou, Shenghao Jin, Linda Fletcher, M. Celeste Simon, and Jeffrey Field
Comparative Evaluation of HERG Currents and QT Intervals following Challenge with Suspected Torsadogenic and Nontorsadogenic Drugs	J. Pharmacol. Exp. Ther. 2006; 316(3): p. 1098-1106	Alexander N. Katchman, John Koerner, Toshimasa Tosaka, Raymond L. Woosley, and Steven N. Ebert
Rap1-Mediated Activation of Extracellular Signal-Regulated Kinases by Cyclic AMP Is Dependent on the Mode of Rap1 Activation	Mol. Cell. Biol. 2006; 26(6): p. 2130-2145	Zhiping Wang, Tara J. Dillon, Viji Pokala, Snigdha Mishra, Kirstin Labudda, Brian Hunter, and Philip J. S. Stork
Changes in chromatin structure and mobility in living cells at sites of DNA double-strand breaks	J. Cell Biol. published 6 March 2006, 10.1083/jcb.200510015	Michael J. Kruhlak, Arkady Celeste, Graham Dellaire, Oscar Fernandez-Capetillo, Waltraud G. Muller, James G. McNally, David P. Bazett-Jones, and Andre Nussenzweig
Genetic ablation of zyxin causes Mena/VASP mislocalization, increased motility, and deficits in actin remodeling	J. Cell Biol. 2006; 172(5): p. 771-782	Laura M. Hoffman, Christopher C. Jensen, Susanne Kloeker, C.-L. Albert Wang, Masaaki Yoshigi, and Mary C. Beckerle
Assembling an intermediate filament network by dynamic cotranslation	J. Cell Biol. 2006; 172(5): p. 747-758	Lynne Chang, Yaron Shav-Tal, Tatjana Trcek, Robert H. Singer, and Robert D. Goldman
A motor neuron disease-associated mutation in p150Glued perturbs dynactin function and induces protein aggregation	J. Cell Biol. 2006; 172(5): p. 733-745	Jennifer R. Levy, Charlotte J. Sumner, Juliane P. Caviston, Mariko K. Tokito, Srikanth Ranganathan, Lee A. Ligon, Karen E. Wallace, Bernadette H. LaMonte, George G. Harmison, Imke Puls, Kenneth H. Fischbeck, and Erika L.F. Holzbaur
Synthetic D-amino acid peptide inhibits tumor cell motility on laminin-5	Carcinogenesis published 14 March 2006, 10.1093/carcin/bgl005	Thomas C. Sroka, Michael E. Pennington, and Anne E. Cress
Evidence that sequence homologous region in LRAT-like proteins possesses anti-proliferative activity and DNA binding properties: translational implications and mechanism of action	Carcinogenesis. 2006; 27(4): p. 693-707	Denise Perry Simmons, Megan L. Peach, Jonathan R. Friedman, Michael M.B. Green, Marc C. Nicklaus, and Luigi M. De Luca
Role of target geometry in phagocytosis	Proc. Natl. Acad. Sci. USA published 20 March 2006, 10.1073/pnas.0600997103	Julie A. Champion and Samir Mitragotri
A physical model of axonal damage due to oxidative stress	Proc. Natl. Acad. Sci. USA published 28 March 2006, 10.1073/pnas.0504134103	Anne E. Counterman, Terrence G. D'Onofrio, Anne Milasincic Andrews, and Paul S. Weiss
Cholesterol Is Required for Efficient Endoplasmic Reticulum-to-Golgi Transport of Secretory Membrane Proteins	Mol. Biol. Cell. 2006; 17(4): p. 1593-1605	Andrew Ridsdale, Maxime Denis, Pierre-Yves Gougeon, Johnny K. Ngsee, John F. Presley, and Xiaohui Zha
Auto-activation of the apoptosis protein BAX increases mitochondrial membrane permeability and is inhibited by BCL-2	J. Biol. Chem. published 29 March 2006, 10.1074/jbc.M602374200	Chibing Tan, Paulina J. Dlugosz, Jun Peng, Zhi Zhang, Suzanne M. Lapolla, Scott M. Plafker, David W. Andrews, and Jialing Lin
The Zn ²⁺ -transporting Pathways in Pancreatic beta-Cells: A ROLE FOR THE L-TYPE VOLTAGE-GATED Ca ²⁺ CHANNEL	J. Biol. Chem. 2006; 281(14): p. 9361-9372	Armen V. Gyulkhandanyan, Simon C. Lee, George Bikopoulos, Feihan Dai, and Michael B. Wheeler



References

In Vivo Dynamics of Rac-Membrane Interactions	Mol. Biol. Cell published 5 April 2006, 10.1091/mbc.E06-01-0005	Konstadinos Moissoglou, Boris M. Stepchenko, Nahum Meller, Alan F. Horwitz, and Martin A. Schwartz
A dynamic ubiquitin equilibrium couples proteasomal activity to chromatin remodeling	J. Cell Biol. 2006; 173(1): p. 19-26	Nico P. Dantuma, Tom A.M. Groothuis, Florian A. Salomons, and Jacques Neefjes
New insights into extracellular matrix assembly and reorganization from dynamic imaging of extracellular matrix proteins in living osteoblasts.	J Cell Sci 1 Apr 2006 119(Pt 7): p. 1350.	P Sivakumar, A Czirok, BJ Rongish, VP Divakara, YP Wang, and SL Dallas
Differential effects of bryostatins 1 and 12-O-tetradecanoylphorbol-13-acetate on the regulation and activation of RasGRP1 in mouse epidermal keratinocytes	Mol Cancer Ther 1 Mar 2006 5(3): p. 602	MC Tuthill, CE Oki, and PS Lorenzo
Spatiotemporal dynamics of p21CDKN1A protein recruitment to DNA-damage sites and interaction with proliferating cell nuclear antigen.	J Cell Sci 15 Apr 2006 119(Pt 8): p. 1517	P Perucca, O Cazzalini, O Mortusewicz, D Necchi, M Savio, T Nardo, LA Stivala, H Leonhardt, MC Cardoso, and E Prosperi
From the Cover: A physical model of axonal damage due to oxidative stress.	Proc Natl Acad Sci U S A 4 Apr 2006 103(14): p. 5262	AE Counterman, TG D'Onofrio, AM Andrews, and PS Weiss
	J Cell Sci 1 Apr 2006 119(Pt 7): p. 1453	E Krieghoff, J Behrens, and B Mayr
A conformational switch in vinculin drives formation and dynamics of a talin-Vinculin complex at focal adhesions	J. Biol. Chem. published 10 April 2006, 10.1074/jbc.M600738200	Daniel M. Cohen, Brett Kutscher, Hui Chen, Douglas B. Murphy, and Susan W. Craig
IB-MECA confers cardioprotection at reperfusion by inhibiting mitochondrial permeability transition pore opening via glycogen synthase kinase 3(beta)	J. Pharmacol. Exp. Ther. published 12 April 2006, 10.1124/jpet.106.101477	Sung-Sik Park, Hong Zhao, Yeongho Jang, Robert A Mueller, and Zhelong Xu
Functional Characterization and Target Validation of Alternative Complex I of Plasmodium falciparum Mitochondria	Antimicrob. Agents Chemother. 2006; 50(5): p. 1841-1851	Giancarlo A. Biagini, Parnpen Viriyavejakul, Paul M. O'Neill, Patrick G. Bray, and Stephen A. Ward
A Functional Module of Yeast Mediator That Governs the Dynamic Range of Heat-Shock Gene Expression	Genetics. 2006; 172(4): p. 2169-2184	Harpreet Singh, Alexander M. Erkine, Selena B. Kremer, Harry M. Duttweiler, Donnie A. Davis, Javed Iqbal, Rachel R. Gross, and David S. Gross
A Role for the Septation Initiation Network in Septum Assembly Revealed by Genetic Analysis of sid2-250 Suppressors	Genetics. 2006; 172(4): p. 2101-2112	Quan-Wen Jin, Mian Zhou, Andrea Bimbo, Mohan K. Balasubramanian, and Dannel McCollum
Caldesmon is an integral component of podosomes in smooth muscle cells.	J Cell Sci 1 May 2006 119(Pt 9): p. 1691	R Eves, BA Webb, S Zhou, and AS Mak
Ordered assembly of the duplicating Golgi in Trypanosoma brucei	Proc. Natl. Acad. Sci. USA published 3 May 2006, 10.1073/pnas.0602595103	Helen H. Ho, Cynthia Y. He, Christopher L. de Graffenried, Lindsay J. Murrells, and Graham Warren
Monoclonal Antibodies for Bacillus anthracis Spore Detection and Functional Analyses of Spore Germination and Outgrowth	J Immunol 15 May 2006 176(10): p. 6076	MK Swiecki, MW Lisanby, F Shu, CL Turnbough Jr, and JF Kearney
Membrane lateral diffusion and capture of CFTR within transient confinement zones	Biophys. J. published 19 May 2006, 10.1529/biophysj.106.084830	Ian R Bates, Benedict Hebert, Yishan Luo, Jie Liao, Alexia I Bachir, David L Koliin, Paul W Wiseman, and John W Hanrahan
Clustering Class I MHC Modulates Sensitivity of T Cell Recognition	J Immunol 1 Jun 2006 176(11): p. 6673	David R Fooksman, Gigi Kwik Gronvall, Qing Tang, and Michael Edidin
Role of Pseudorabies Virus Us3 Protein Kinase during Neuronal Infection	J Virol 1 Jul 2006 80(13): p. 6387.	LM Olsen, TH Ch'ng, JP Card, and LW Enquist
N6-(3-Iodobenzyl)-adenosine-5'-N-methylcarboxamide Confers Cardioprotection at Reperfusion by Inhibiting Mitochondrial Permeability Transition Pore Opening via Glycogen Synthase Kinase 3beta	J Pharmacol Exp Ther 1 Jul 2006 318(1): p. 124	SS Park, H Zhao, Y Jang, RA Mueller, and Z Xu
Differential effect of bryostatins 1 and phorbol 12-myristate 13-acetate on HOP-92 cell proliferation is mediated by down-regulation of protein kinase Cdelta	Cancer Res 15 Jul 2006 66(14): p. 7261	SH Choi, T Hyman, and PM Blumberg
A conformational switch in vinculin drives formation and dynamics of a talin-vinculin complex at focal adhesions	J Biol Chem 9 Jun 2006 281(23): p. 16006.	DM Cohen, B Kutscher, H Chen, DB Murphy, and SW Craig
Requirement of Nck adaptors for actin dynamics and cell migration stimulated by platelet-derived growth factor B	Proc. Natl. Acad. Sci. USA. 2006; 103(25): p. 9536-9541	G. M. Rivera, S. Antoku, S. Gelpok, N. Y. Shin, S. K. Hanks, T. Pawson, and B. J. Mayer
R7BP augments the function of RGS7/Gbeta 5 complexes by a plasma-membrane targeting mechanism	J. Biol. Chem. published 25 July 2006, 10.1074/jbc.M604428200	Ryan M. Drenan, Craig A. Doupnik, Muralidharan Jayaraman, Abigail L. Buchwalter, Kevin M. Kaltenbronn, James E. Huettner, Maurine E. Linder, and Kendall J. Blumer
Multiprotein Complexes of the Survival of Motor Neuron Protein SMN with Gemins Traffic to Neuronal Processes and Growth Cones of Motor Neurons	J. Neurosci. 2006; 26(33): p. 8622-8632	Honglai Zhang, Lei Xing, Wilfried Rossoll, Hynek Wichterle, Robert H. Singer, and Gary J. Bassell
A Coiled-Coil Domain of Melanophilin Is Essential for Myosin Va Recruitment and Melanosome Transport in Melanocytes	Mol. Biol. Cell published 16 August 2006, 10.1091/mbc.E06-05-0457	Alistair N. Hume, Abul K. Tarafder, Jose S. Ramalho, Elena V. Sviderskaya, and Miguel C. Seabra
Architecture of the vimentin cytoskeleton is modified by perturbation of the GTPase ARF1	J. Cell Sci. 2006; 119(17): p. 3643-3654	Melanie L. Styers, Andrew P. Kowalczyk, and Victor Faundez
Calcium Signaling In Human Airway Goblet Cells Following Purinergic Activation	AJP: Lung published 1 September 2006, 10.1152/ajplung.00081.2006	Andrea H. Rossi, Wendy C. Salmon, Michael Chua, and C. William Davis
GBF1, a cis-Golgi and VTCs-localized ARF-GEF, is implicated in ER-to-Golgi protein traffic	J. Cell Sci. 2006; 119(18): p. 3743-3753	Xinhua Zhao, Alejandro Claude, Justin Chun, David J. Shields, John F. Presley, and Paul Melancon

This is not a complete list of Bioprotech's references, a keyword searchable database with these and hundreds of other references are available on the Bioprotech web site. www.bioprotech.com



